



COVER SHEET

Proposal Submitted By:

Contractor's Name

Contractor's Address

City

State

Zip Code

STATE OF ILLINOIS

Local Public Agency

County

LaSalle

Section Number

23-00409-00-RS

Route(s) (Street/Road Name)

County Highway 15

Type of Funds

MFT

Proposal Only Proposal and Plans Proposal only, plans are separate

Submitted/Approved

For Local Public Agency:

For a County and Road District Project

Submitted/Approved

Highway Commissioner Signature & Date

Submitted/Approved

County Engineer/Superintendent of Highways Signature & Date

 5/3/2024

For a Municipal Project

Submitted/Approved/Passed

Signature & Date

Official Title

Department of Transportation

Released for bid based on limited review

Regional Engineer Signature & Date

Note: All proposal documents, including Proposal Guaranty Checks or Proposal Bid Bonds, should be stapled together to prevent loss when bids are processed.

Bid Submittal Checklist
Contract Sections

Use the following checklist to assure completeness and correct order in assembling your bid

- BLR 12200 – Proposal / Contract Cover
- BLR 12200 – Notice to Bidders
- BLR 12200 – Proposal
- BLR 12200 – Contractor Certifications
- BLR 12200 – Signatures
- BLR 12201 – Schedule of Prices
- BLR 12230 – Proposal Bid Bond (or Bid Check if applicable)
- BLR 12325 – Apprenticeship or Training Program Certification
- BLR 12326 – Affidavit of Illinois Business Office
- BC 261 – Substance Abuse Prevention Program Certification

**THE USE OF FORMS OTHER THAN THOSE
PROVIDED WILL RESULT IN YOUR BID BEING
REJECTED.**

Local Public Agency	County	Section Number	Route(s) (Street/Road Name)
	LaSalle	23-00409-00-RS	County Highway 15

NOTICE TO BIDDERS

Sealed proposals for the project described below will be received at the office of the LaSalle County Engineer
 1400 N.27th Road, Ottawa, IL 61350 Name of Office
 _____ until 9:00 AM on 05/15/24
Address Time Date

Sealed proposals will be opened and read publicly at the office of the LaSalle County Engineer
 1400 N.27th Road, Ottawa, IL 61350 Name of Office
 _____ at 9:00 AM on 05/15/24
Address Time Date

DESCRIPTION OF WORK

Location	Project Length
County Highway 15	0.904 miles

Proposed Improvement
 The work consists of cold milling and HMA paving of the roadway surface.

1. Plans and proposal forms will be available in the office of
 The LaSalle County Engineer, 1400 N.27th Road, Ottawa, IL 61350

2. Prequalification
 If checked, the 2 apparent as read low bidders must file within 24 hours after the letting an "Affidavit of Availability" (Form BC 57) in triplicate, showing all uncompleted contracts awarded to them and all low bids pending award for Federal, State, County, Municipal and private work. One original shall be filed with the Awarding Authority and two originals with the IDOT District Office.
3. The Awarding Authority reserves the right to waive technicalities and to reject any or all proposals as provided in BLRS Special Provision for Bidding Requirements and Conditions for Contract Proposals.
4. The following BLR Forms shall be returned by the bidder to the Awarding Authority:
 - a. Local Public Agency Formal Contract Proposal (BLR 12200)
 - b. Schedule of Prices (BLR 12201)
 - c. Proposal Bid Bond (BLR 12230) (if applicable)
 - d. Apprenticeship or Training Program Certification (BLR 12325) (do not use for project with Federal funds.)
 - e. Affidavit of Illinois Business Office (BLR 12326) (do not use for project with Federal funds)
5. The quantities appearing in the bid schedule are approximate and are prepared for the comparison of bids. Payment to the Contractor will be made only for the actual quantities of work performed and accepted or materials furnished according to the contract. The scheduled quantities of work to be done and materials to be furnished may be increased, decreased or omitted as hereinafter provided.
6. Submission of a bid shall be conclusive assurance and warranty the bidder has examined the plans and understands all requirements for the performance of work. The bidder will be responsible for all errors in the proposal resulting from failure or neglect to conduct an in depth examination. The Awarding Authority will, in no case, be responsible for any costs, expenses, losses or changes in anticipated profits resulting from such failure or neglect of the bidder.
7. The bidder shall take no advantage of any error or omission in the proposal and advertised contract.
8. If a special envelope is supplied by the Awarding Authority, each proposal should be submitted in that envelope furnished by the Awarding Agency and the blank spaces on the envelope shall be filled in correctly to clearly indicate its contents. When an envelope other than the special one furnished by the Awarding Authority is used, it shall be marked to clearly indicate its contents. When sent by mail, the sealed proposal shall be addressed to the Awarding Authority at the address and in care of the official in whose office the bids are to be received. All proposals shall be filed prior to the time and at the place specified in the Notice to Bidders. Proposals received after the time specified will be returned to the bidder unopened.
9. Permission will be given to a bidder to withdraw a proposal if the bidder makes the request in writing or in person before the time for opening proposals.

Local Public Agency	County	Section Number	Route(s) (Street/Road Name)
	LaSalle	23-00409-00-RS	County Highway 15

PROPOSAL

1. Proposal of _____ Contractor's Name _____

Contractor's Address _____

2. The plans for the proposed work are those prepared by _____ and approved by the Department of Transportation on _____.

3. The specifications referred to herein are those prepared by the Department of Transportation and designated as "Standard Specifications for Road and Bridge Construction" and the " Supplemental Specifications and Recurring Special Provisions" thereto, adopted and in effect on the date of invitation for bids.

4. The undersigned agrees to accept, as part of the contract, the applicable Special Provisions indicated on the "Check Sheet for Recurring Special Provisions" contained in this proposal.

5. The undersigned agrees to complete the work within 15 working days or by _____ unless additional time is granted in accordance with the specifications.

6. The successful bidder at the time of execution of the contract will be required to deposit a contract bond for the full amount of the award. When a contract bond is not required, the proposal guaranty check will be held in lieu thereof. If this proposal is accepted and the undersigned fails to execute a contract and contract bond as required, it is hereby agreed that the Bid Bond of check shall be forfeited to the Awarding Authority.

7. Each pay item should have a unit price and a total price. If no total price is shown or if there is a discrepancy between the products of the unit price multiplied by the quantity, the unit price shall govern. If a unit price is omitted, the total price will be divided by the quantity in order to establish a unit price. A bid may be declared unacceptable if neither a unit price nor a total price is shown.

8. The undersigned submits herewith the schedule of prices on BLR 12201 covering the work to be performed under this contract.

9. The undersigned further agrees that if awarded the contract for the sections contained in the combinations on BLR 12201, the work shall be in accordance with the requirements of each individual proposal for the multiple bid specified in the Schedule for Multiple Bids below.

10. A proposal guaranty in the proper amount, as specified in BLRS Special Provision for Bidding Requirements and Conditions for Contract Proposals, will be required. Bid Bonds will be allowed as a proposal guaranty. Accompanying this proposal is either a bid bond, if allowed, on Department form BLR 12230 or a proposal guaranty check, complying with the specifications, made payable to: LaSalle County Treasurer of LaSalle County.

The amount of the check is _____ (_____).

Attach Cashier's Check or Certified Check Here

In the event that one proposal guaranty check is intended to cover two or more bid proposals, the amount must be equal to the sum of the proposal guaranties which would be required for each individual bid proposal. If the proposal guaranty check is placed in another bid proposal, state below where it may be found.

The proposal guaranty check will be found in the bid proposal for: Section Number _____.

Local Public Agency	County	Section Number	Route(s) (Street/Road Name)
	LaSalle	23-00409-00-RS	County Highway 15

CONTRACTOR CERTIFICATIONS

The certifications hereinafter made by the bidder are each a material representation of fact upon which reliance is placed should the Department enter into the contract with the bidder.

1. **Debt Delinquency.** The bidder or contractor or subcontractor, respectively, certifies that it is not delinquent in the payment of any tax administered by the Department of Revenue unless the individual or other entity is contesting, in accordance with the procedure established by the appropriate Revenue Act, its liability for the tax or the amount of the tax. Making a false statement voids the contract and allows the Department to recover all amounts paid to the individual or entity under the contract in a civil action.
2. **Bid-Rigging or Bid Rotating.** The bidder or contractor or subcontractor, respectively, certifies that it is not barred from contracting with the Department by reason of a violation of either 720 ILCS 5/33E-3 or 720 ILCS 5/33E-4.

A violation of section 33E-3 would be represented by a conviction of the crime of bid-rigging which, in addition to Class 3 felony sentencing, provides that any person convicted of this offense, or any similar offense of any state or the United States which contains the same elements as this offense shall be barred for 5 years from the date of conviction from contracting with any unit of State or local government. No corporation shall be barred from contracting with any unit of State or local government as a result of a conviction under this Section of any employee or agent of such corporation if the employee so convicted is no longer employed by the corporation: (1) it has been finally adjudicated not guilty or (2) if it demonstrates to the governmental entity with which it seeks to contract that entity finds that the commission of the offense was neither authorized, requested, commanded, nor performed by a director, officer or a high managerial agent on behalf of the corporation.

A violation of Section 33E-4 would be represented by a conviction of the crime of bid-rotating which, in addition to Class 2 felony sentencing, provides that any person convicted of this offense or any similar offense of any state or the United States which contains the same elements as this offense shall be permanently barred from contracting with any unit of State of Local government. No corporation shall be barred from contracting with any unit of State or Local government as a result of a conviction under this Section of any employee or agent of such corporation if the employee so convicted is no longer employed by the corporation and: (1) it has been finally adjudicated not guilty or (2) if it demonstrates to the governmental entity with which it seeks to contract and that entity finds that the commission of the offense was neither authorized, requested, commanded, nor performed by a director, officer or a high managerial agent on behalf of the corporation.

3. **Bribery.** The bidder or contractor or subcontractor, respectively, certifies that, it has not been convicted of bribery or attempting to bribe an officer or employee of the State of Illinois or any unit of local government, nor has the firm made an admission of guilt of such conduct which is a matter of record, nor has an official, agent, or employee of the firm committed bribery or attempted bribery on behalf of the firm and pursuant to the direction or authorization of a responsible official of the firm.
4. **Interim Suspension or Suspension.** The bidder or contractor or subcontractor, respectively, certifies that it is not currently under a suspension as defined in Subpart I of Title 44 Subtitle A Chapter III Part 6 of the Illinois Administrative code. Furthermore, if suspended prior to completion of this work, the contract or contracts executed for the completion of this work may be canceled.

Local Public Agency	County	Section Number	Route(s) (Street/Road Name)
	LaSalle	23-00409-00-RS	County Highway 15

SIGNATURES

(If an individual)

Bidder Signature & Date

Business Address

City State Zip Code

(If a partnership)

Firm Name

Signature & Date

Title

Business Address

City State Zip Code

Insert the Names and Addresses of all Partners

(If a corporation)

Corporate Name

Signature & Date

Title

Business Address

City State Zip Code

Insert Names of Officers

President

Secretary

Treasurer

Attest:

Secretary



Contractor's Name

Contractor's Address

City

State

Zip Code

Local Public Agency

County

Section Number

Route(s) (Street/Road Name)

County Highway 15

Schedule for Multiple Bids

Combination Letter	Section Included in Combinations	Total

Schedule for Single Bid

(For complete information covering these items, see plans and specifications.)

Item Number	Items	Unit	Quantity	Unit Price	Total
20200500	Earth Excavation (Widening)	Cu Yd	3		
40600275	Bit Matls (Prime Coat)	Pound	119		
40600290	Bit Matls (Tack Coat)	Pound	5965		
40600370	Long Joint Sealant	Foot	4722		
40600982	HMA Removal-Butt Joint	Sq Yd	53		
40604050	HMA Surf Cse,IL-9.5, "C", N50	Ton	1116		
44000152	HMA Surf Removal, 3/4"	Sq Yd	11440		
44000155	HMA Surf Removal, 1 1/4"	Sq Yd	2457		
48101200	Agg Shoulders, Ty B	Ton	204		
70300100	Short-Term Pavt Mking	Foot	2322		
78001110	Paint Pavt Mk-Line 4"	Foot	5626		
78001130	Paint Pavt Mk-Line 6"	Foot	8977		
78004280	Pref PI Pavt Mk, Ty B Inl L 24	Foot	49		
X4401198	HMA Surf Rem-Variable Depth	Sq Yd	194		
Bidder's Total Proposal					

1. Each pay item should have a unit price and a total price.
2. If no total price is shown or if there is a discrepancy between the product of the unit price multiplied by the quantity, the unit price shall govern.
3. If a unit price is omitted, the total price will be divided by the quantity in order to establish a unit price.
4. A bid may be declared unacceptable if neither a unit price or total price is shown.



Local Public Agency Proposal Bid Bond

Local Public Agency _____ County LaSalle Section Number 23-00409-00-RS

WE, _____ as PRINCIPAL, and _____ as SURETY, are held jointly, severally and firmly bound unto the above Local Public Agency (hereafter referred to as "LPA") in the penal sum of 5% of the total bid price, or for the amount specified in the proposal documents in effect on the date of invitation for bids, whichever is the lesser sum. We bind ourselves, our heirs, executors, administrators, successors, and assigns, jointly pay to the LPA this sum under the conditions of this instrument.

WHEREAS THE CONDITION OF THE FOREGOING OBLIGATION IS SUCH that, the said PRINCIPAL is submitting a written proposal to the LPA acting through its awarding authority for the construction of the work designated as the above section.

THEREFORE if the proposal is accepted and a contract awarded to the PRINCIPAL by the LPA for the above designated section and the PRINCIPAL shall within fifteen (15) days after award enter into a formal contract, furnish surety guaranteeing the faithful performance of the work, and furnish evidence of the required insurance coverage, all as provided in the "Standard Specifications for Road and Bridge Construction" and applicable Supplemental Specifications, then this obligation shall become void; otherwise it shall remain in full force and effect.

IN THE EVENT the LPA determines the PRINCIPAL has failed to enter into a formal contract in compliance with any requirements set forth in the preceding paragraph, then the LPA acting through its awarding authority shall immediately be entitled to recover the full penal sum set out above, together with all court costs, all attorney fees, and any other expense of recovery.

IN TESTIMONY WHEREOF, the said PRINCIPAL and the said SURETY have caused this instrument to be signed by their respective officers this _____ of _____ Day Month and Year

Principal

Company Name _____ Signature & Date _____ By: _____ Title _____

Company Name _____ Signature & Date _____ By: _____ Title _____

(If Principal is a joint venture of two or more contractors, the company names, and authorized signatures of each contractor must be affixed.)

Surety

Name of Surety _____

Signature of Attorney-in-Fact Signature & Date _____ By: _____

STATE OF IL COUNTY OF

I _____, a Notary Public in and for said county do hereby certify that

(Insert names of individuals signing on behalf of PRINCIPAL & SURETY)

who are each personally known to me to be the same persons whose names are subscribed to the foregoing instrument on behalf of PRINCIPAL and SURETY, appeared before me this day in person and acknowledged respectively, that they signed and delivered said instruments as their free and voluntary act for the uses and purposes therein set forth.

Given under my hand and notarial seal this _____ Day of _____ Month and Year

(SEAL, if required by the LPA)

Notary Public Signature & Date _____

Date commission expires _____

Local Public Agency

County

LaSalle

Section Number

23-00409-00-RS

ELECTRONIC BID BOND

Electronic bid bond is allowed (box must be checked by LPA if electronic bid bond is allowed)

The Principal may submit an electronic bid bond, in lieu of completing the above section of the Proposal Bid Bond Form. By providing an electronic bid bond ID code and signing below, the Principal is ensuring the identified electronic bid bond has been executed and the Principal and Surety are firmly bound unto the LPA under the conditions of the bid bond as shown above. (If PRINCIPAL is a joint venture of two or more contractors, an electronic bid bond ID code, company/Bidder name title and date must be affixed for each contractor in the venture.)

Electronic Bid Bond ID Code

--	--	--	--	--	--	--	--	--	--	--	--	--	--	--	--	--	--	--	--

Company/Bidder Name

Signature & Date

Title



Apprenticeship and Training Program Certification

Local Public Agency	County	Street Name/Road Name	Section Number
	LaSalle	County Highway 15	23-00409-00-RS

All contractors are required to complete the following certification

- For this contract proposal or for all bidding groups in this deliver and install proposal.
- For the following deliver and install bidding groups in this material proposal.

Illinois Department of Transportation policy, adopted in accordance with the provisions of the Illinois Highway Code, requires this contract to be awarded to the lowest responsive and responsible bidder. The award decision is subject to approval by the Department. In addition to all other responsibility factors, this contract or deliver and install proposal requires all bidders and all bidder's subcontractors to disclose participation in apprenticeship or training programs that are (1) approved by and registered with the United States Department of Labor's Bureau of Apprenticeship and Training, and (2) applicable to the work of the above indicated proposals or groups. Therefore, all bidders are required to complete the following certification:

1. Except as provided in paragraph 4 below, the undersigned bidder certifies that it is a participant, either as an individual or as part of a group program, in an approved apprenticeship or training program applicable to each type of work or craft that the bidder will perform with its own employees.
2. The undersigned bidder further certifies, for work to be performed by subcontract, that each of its subcontractors either (A) is, at the time of such bid, participating in an approved, applicable apprenticeship or training program; or (B) will, prior to commencement of performance of work pursuant to this contract, establish participation in an approved apprenticeship or training program applicable to the work of the subcontract.
3. The undersigned bidder, by inclusion in the list in the space below, certifies the official name of each program sponsor holding the Certificate of Registration for all of the types of work or crafts in which the bidder is a participant and that will be performed with the bidder's employees. Types of work or craft that will be subcontracted shall be included and listed as subcontract work. The list shall also indicate any type of work or craft job category for which there is no applicable apprenticeship or training program available.

4. Except for any work identified above, if any bidder or subcontractor shall perform all or part of the work of the contract or deliver and install proposal solely by individual owners, partners or members and not by employees to whom the payment of prevailing rates of wages would be required, check the following box, and identify the owner/operator workforces and positions of ownership.

The requirements of this certification and disclosure are a material part of the contract, and the contractor shall require this certification provision to be included in all approved subcontracts. The bidder is responsible for making a complete report and shall make certain that each type of work or craft job category that will be utilized on the project is accounted for and listed. The Department at any time before or afterward may require the production of a copy of each applicable Certificate of Registration issued by the United States Department of Labor evidencing such participation by the contractor and any or all of its subcontractors. In order to fulfill the participation requirement, it shall not be necessary that any applicable program sponsor be currently taking or that it will take applications for apprenticeship, training or employment during the performance of the work of this contract or deliver and install proposal.

Bidder	Signature & Date		
Title			
Address	City	State	Zip Code



Local Public Agency	County	Street Name/Road Name	Section Number
	LaSalle	County Highway 15	23-00409-00-RS

I, _____ of _____, _____,
Name of Affiant City of Affiant State of Affiant
 being first duly sworn upon oath, state as follows:

1. That I am the _____ of _____.
Officer or Position Bidder
2. That I have personal knowledge of the facts herein stated.
3. That, if selected under the proposal described above, _____, will maintain a business office in the
Bidder
 State of Illinois, which will be located in _____ County, Illinois.
County
4. That this business office will serve as the primary place of employment for any persons employed in the construction contemplated by this proposal.
5. That this Affidavit is given as a requirement of state law as provided in Section 30-22(8) of the Illinois Procurement Code.

Signature & Date

Print Name of Affiant

Notary Public

State of IL

County _____

Signed (or subscribed or attested) before me on _____ by
(date)

_____, authorized agent(s) of
(name/s of person/s)

Bidder

Notary Public Signature & Date

(SEAL)

My commission expires _____



Substance Abuse Prevention Program Certification



Contract Number	District	Letting Date
	3	05/15/24
Route	County	
County Highway 15	LaSalle	
Project Number	Job Number	
Section Number		
23-00409-00-RS		

The Substance Abuse Prevention on Public Works Act, Public Act 95-0635, prohibits the use of drugs and alcohol, as defined in the Act, by employees of the Contractor and by employees of all approved Subcontractors while performing work on a public works project. The Contractor/Subcontractor herewith certifies that it has a superseding collective bargaining agreement or makes the public filing of its written substance abuse prevention program for the prevention of substance abuse among its employees who are not covered by a collective bargaining agreement dealing with the subject as mandated by the Act.

A. The undersigned representative of the Contractor/Subcontractor certifies that the contracting entity has signed collective bargaining agreements that are in effect for all of its employees, and that deal with the subject matter of Public Act 95-0635.

Contractor/Subcontractor

Name of Authorized Representative (type or print)

Title of Authorized Representative (type or print)

Signature of Authorized Representative

Date

B. The undersigned representative of the Contractor/Subcontractor certifies that the contracting entity has in place for all of its employees not covered by a collective bargaining agreement that deals with the subject of the Act, the attached substance abuse prevention program that meets or exceeds the requirements of Public Act 95-0635.

Contractor/Subcontractor

Name of Authorized Representative (type or print)

Title of Authorized Representative (type or print)

Signature of Authorized Representative

Date

INDEX
FOR
SUPPLEMENTAL SPECIFICATIONS
AND RECURRING SPECIAL PROVISIONS

Adopted January 1, 2024

This index contains a listing of SUPPLEMENTAL SPECIFICATIONS, frequently used RECURRING SPECIAL PROVISIONS, and LOCAL ROADS AND STREETS RECURRING SPECIAL PROVISIONS.

ERRATA Standard Specifications for Road and Bridge Construction
(Adopted 1-1-22) (Revised 1-1-24)

SUPPLEMENTAL SPECIFICATIONS

<u>Std. Spec. Sec.</u>	<u>Page No.</u>
202 Earth and Rock Excavation	1
204 Borrow and Furnished Excavation	2
207 Porous Granular Embankment	3
211 Topsoil and Compost	4
407 Hot-Mix Asphalt Pavement (Full-Depth)	5
420 Portland Cement Concrete Pavement	6
502 Excavation for Structures	7
509 Metal Railings	8
540 Box Culverts	9
542 Pipe Culverts	29
586 Granular Backfill for Structures	34
630 Steel Plate Beam Guardrail	35
644 High Tension Cable Median Barrier	36
665 Woven Wire Fence	37
782 Reflectors	38
801 Electrical Requirements	40
821 Roadway Luminaires	43
1003 Fine Aggregates	44
1004 Coarse Aggregates	45
1010 Finely Divided Minerals	46
1020 Portland Cement Concrete	47
1030 Hot-Mix Asphalt	48
1061 Waterproofing Membrane System	49
1067 Luminaire	50
1097 Reflectors	57



Check Sheet for Recurring Special Provisions

Local Public Agency	County	Section Number
	LaSalle	23-00409-00-RS

Check this box for lettings prior to 01/01/2024.

The Following Recurring Special Provisions Indicated By An "X" Are Applicable To This Contract And Are Included By Reference:

Recurring Special Provisions

Check Sheet #		Page No.
1	<input type="checkbox"/> Additional State Requirements for Federal-Aid Construction Contracts	59
2	<input type="checkbox"/> Subletting of Contracts (Federal-Aid Contracts)	62
3	<input type="checkbox"/> EEO	63
4	<input type="checkbox"/> Specific EEO Responsibilities Non Federal-Aid Contracts	73
5	<input type="checkbox"/> Required Provisions - State Contracts	78
6	<input type="checkbox"/> Asbestos Bearing Pad Removal	84
7	<input type="checkbox"/> Asbestos Waterproofing Membrane and Asbestos HMA Surface Removal	85
8	<input type="checkbox"/> Temporary Stream Crossings and In-Stream Work Pads	86
9	<input type="checkbox"/> Construction Layout Stakes	87
10	<input type="checkbox"/> Use of Geotextile Fabric for Railroad Crossing	90
11	<input type="checkbox"/> Subsealing of Concrete Pavements	92
12	<input type="checkbox"/> Hot-Mix Asphalt Surface Correction	96
13	<input type="checkbox"/> Pavement and Shoulder Resurfacing	98
14	<input type="checkbox"/> Patching with Hot-Mix Asphalt Overlay Removal	99
15	<input type="checkbox"/> Polymer Concrete	101
16	<input type="checkbox"/> Reserved	103
17	<input type="checkbox"/> Bicycle Racks	104
18	<input type="checkbox"/> Temporary Portable Bridge Traffic Signals	106
19	<input type="checkbox"/> Nighttime Inspection of Roadway Lighting	108
20	<input type="checkbox"/> English Substitution of Metric Bolts	109
21	<input type="checkbox"/> Calcium Chloride Accelerator for Portland Cement Concrete	110
22	<input type="checkbox"/> Quality Control of Concrete Mixtures at the Plant	111
23	<input type="checkbox"/> Quality Control/Quality Assurance of Concrete Mixtures	119
24	<input type="checkbox"/> Reserved	135
25	<input type="checkbox"/> Reserved	136
26	<input type="checkbox"/> Temporary Raised Pavement Markers	137
27	<input type="checkbox"/> Restoring Bridge Approach Pavements Using High-Density Foam	138
28	<input type="checkbox"/> Portland Cement Concrete Inlay or Overlay	141
29	<input type="checkbox"/> Portland Cement Concrete Partial Depth Hot-Mix Asphalt Patching	145
30	<input type="checkbox"/> Longitudinal Joint and Crack Patching	148
31	<input type="checkbox"/> Concrete Mix Design - Department Provided	150
32	<input type="checkbox"/> Station Numbers in Pavements or Overlays	151

Local Public Agency	County	Section Number
	LaSalle	23-00409-00-RS

The Following Local Roads And Streets Recurring Special Provisions Indicated By An "X" Are Applicable To This Contract And Are Included By Reference:

Local Roads And Streets Recurring Special Provisions

<u>Check Sheet #</u>		<u>Page No.</u>
LRS 1	Reserved	153
LRS 2	<input type="checkbox"/> Furnished Excavation	154
LRS 3	<input checked="" type="checkbox"/> Work Zone Traffic Control Surveillance	155
LRS 4	<input checked="" type="checkbox"/> Flaggers in Work Zones	156
LRS 5	<input checked="" type="checkbox"/> Contract Claims	157
LRS 6	<input checked="" type="checkbox"/> Bidding Requirements and Conditions for Contract Proposals	158
LRS 7	<input type="checkbox"/> Bidding Requirements and Conditions for Material Proposals	164
LRS 8	Reserved	170
LRS 9	<input type="checkbox"/> Bituminous Surface Treatments	171
LRS 10	Reserved	175
LRS 11	<input checked="" type="checkbox"/> Employment Practices	176
LRS 12	<input checked="" type="checkbox"/> Wages of Employees on Public Works	178
LRS 13	<input checked="" type="checkbox"/> Selection of Labor	180
LRS 14	<input type="checkbox"/> Paving Brick and Concrete Paver Pavements and Sidewalks	181
LRS 15	<input checked="" type="checkbox"/> Partial Payments	184
LRS 16	<input checked="" type="checkbox"/> Protests on Local Lettings	185
LRS 17	<input checked="" type="checkbox"/> Substance Abuse Prevention Program	186
LRS 18	<input type="checkbox"/> Multigrade Cold Mix Asphalt	187
LRS 19	<input type="checkbox"/> Reflective Crack Control Treatment	188

INDEX
OF
SPECIAL PROVISIONS

<u>SPECIAL PROVISIONS</u>	<u>PAGE NO.</u>
Description of Proposed Improvement	1
Responsible Bidder	1
Prevailing Wages	1
Insurance	2
Subcontractors and Material Suppliers	2
Protection and Restoration of Property	2
Prosecution of Work	3
Working Days	3
Traffic Control Plan	3, 4 & 5
Hot-Mix Asphalt Surface Removal	5
Mobilization	5
Short Term Pavement Marking	5



Local Public Agency

County

Section Number

The following Special Provision supplement the "Standard Specifications for Road and Bridge Construction", adopted January 1, 2022, the latest edition of the "Manual on Uniform Traffic Control Devices for Streets and Highways", and the "Manual of Test Procedures of Materials" in effect on the date of invitation of bids, and the Supplemental Specification and Recurring Special Provisions indicated on the Check Sheet included here in which apply to and govern the construction of the above named section, and in case of conflict with any parts, or parts of said Specifications, the said Special Provisions shall take precedence and shall govern.

DESCRIPTION OF PROPOSED IMPROVEMENT

The work included in this contract consists of furnishing all labor, equipment, and materials necessary to mill the existing bituminous surface and to construct a hot-mix asphalt surface course, hot-mix asphalt surface removal, aggregate shoulders and other miscellaneous construction.

RESPONSIBLE BIDDER

The Contractor shall have on file, at the LaSalle County Highway Department, a STATEMENT OF COMPLIANCE establishing adherence to the LaSalle County Resolution titled "A RESOLUTION DEFINING RESPONSIBLE BIDDER". The Contractor shall comply with the conditions of the resolution for the duration of the work.

PREVAILING WAGES

This contract calls for the construction of a "public work," within the meaning of the Illinois Prevailing Wage Act, 820 ILCS 130/.01 *et seq.* ("the Act"). The Act requires contractors and subcontractors to pay laborers, workers and mechanics performing services on public works projects no less than the current "prevailing rate of wages" (hourly cash wages plus amount for fringe benefits) in the county where the work is performed. The Illinois Department of Labor publishes the prevailing wage rates on its website at: <https://www2.illinois.gov/idol/Laws-Rules/CONMED/Pages/Rates.aspx>.

The Illinois Department of Labor revises the prevailing wage rates and the contractor/subcontractor has an obligation to check the Illinois Department of Labor's website for revisions to the prevailing wage rates. For information regarding current prevailing wage rates, please refer to the Illinois Department of Labor's website. All contractors and subcontractors rendering services under this contract must comply with all requirements of the Act, *including but not limited to*, all wage requirements and notice and record keeping duties. **Certified payrolls shall be required per Check Sheet LRS 12.**

The monthly updates can also be obtained at the following location;

Office of the LaSalle County Clerk
707 Etna Road
Ottawa, IL 61350
Tel. (815) 434-8202

INSURANCE

Revise Article 107.27 of the "Standard Specifications" as follows:

Change the third and fourth sentences of the first paragraph to:

"The minimum acceptable insurance company rating shall be A as rated by A.M. Best Co."

Add the following to Article 107.27:

"The Contractor and Subcontractors shall waive subrogation on workers compensation." A statement concerning the waiver shall be shown on the insurance certificate.

"County of LaSalle shall be listed as primary additionally insured on all policies."

"County of LaSalle shall be listed as the Certificate Holder on all policies."

"The minimum umbrella liability limit shall be \$1,000,000."

"The County of LaSalle and their officers, employees, and agents shall be indemnified and held harmless in accordance with Article 107.26."

Certificates of insurance and endorsements shall be emailed to mail@lasallegov.com, the subject of the email shall be "Section 23-00409-00-RS, County Highway 15, Certificate of Insurance".

NOTE: The insurance requirements as described herein are illustrated in the Sample Certificate of Liability of Insurance included in this proposal. It is understood that the sample certificate is for information purposes only and includes only the minimum insurance coverage required.

SUBCONTRACTORS AND MATERIAL SUPPLIERS

Prior to execution of the contract by the awarding authority, the Contractor shall provide the names and addresses of all Subcontractors and Material Suppliers for approval. No changes to the approved list shall be made without written consent of the Engineer.

Final payment will be withheld until the Contractor, all Subcontractors, and Material Suppliers have provided Affidavits stating that all sums claimed on account of this improvement are paid.

PROTECTION AND RESTORATION OF PROPERTY

Special attention is called to Article 107.20, paragraphs three and four. In addition, no parking of vehicles and equipment on private property will be allowed without the consent of the property owner.

PROSECUTION OF WORK

Revise the first sentence of Article 108.03 of the Standard Specifications to read:

“After award of the contract, the Contractor shall begin work to be performed under said contract within ten (10) days of a written Notice to Proceed.”

WORKING DAYS

The Contractor shall complete the work within 15 working days. Work shall commence in accordance with the Prosecution of Work requirements and continue uninterrupted unless conditions listed in Article 108.04 (a) or (b) are encountered.

TRAFFIC CONTROL PLAN

Traffic control shall be in accordance with the applicable sections of the Standard Specifications for Road and Bridge Construction, the applicable guidelines contained in the National Manual on Uniform Traffic Control Devices for Streets and Highways, Illinois Supplement to the National Manual on Uniform Traffic Control Devices, these special provisions, and any special details and Highway Standards contained herein and in the plans.

Special attention is called to Article 105.03(b), 107.09, 107.14 and Section 701 of the Standard Specifications for Road and Bridge Construction along with the Bureau of Local Roads and Streets Special Provision for Construction and Maintenance Signs (LR 702).

Standards:

701006-05 701011-04 701201-05 701301-04 701306-04 701311-03 701901-09

Signs:

WORK LIMIT signs shall be furnished and individually post mounted at locations designated by the Engineer. The Engineer will furnish all information needed to complete the signs.

FRESH OIL signs (W21-2) shall be placed at intersections and as required by the Engineer.

LOW SHOULDER signs (W8-9) shall be furnished and individually post mounted. The Contractor shall place the signs at the beginning of the resurface area, just beyond each major intersection and at such locations as directed by the Engineer.

Where construction operations on two-lane roads open to traffic result in the removal or covering of any pavement striping indicating passing restrictions, **NO PASSING ZONES NOT STRIPED NEXT ____ MILES** signs (G20-I100) shall be used. The Contractor shall place the signs at the beginning of the unstriped area, just beyond each major intersection within the unstriped area, and at such other locations as the Engineer may direct to ensure a minimum spacing of five miles. The signs shall be placed just prior to removal or covering of the stripe and shall remain in place until full no-passing zone striping has been restored.

TRAFFIC CONTROL PLAN (cont'd)

If covering existing signs, no tape shall be used on the reflective portion of the sign.

General:

No work shall begin until all traffic control devices are in place and have been approved by the Engineer.

At the pre-construction meeting, the Contractor shall furnish the name of the individual in his direct employ who is to be responsible for the installation and maintenance of the traffic control for this project. If the actual installation and maintenance are to be accomplished by a subcontractor, consent shall be requested of the Engineer at the time of the preconstruction meeting in accordance with Article 108.01 of the Standard Specifications for Road and Bridge Construction. This shall not relieve the Contractor of the foregoing requirements for a responsible individual in his direct employ. Said individual shall be available 24 hours per day.

The Contractor will be required to remove all traffic control devices which were furnished, installed or maintained by him under this contract and such devices shall remain the property of the Contractor upon said removal. All traffic control devices must remain in place until specific authorization for removal is received from the Engineer.

All signs, barricades and other traffic control devices shall be new or in like new condition.

Traffic Control Deficiency Deduction:

When the Engineer is notified, or determines that a traffic control deficiency exists, he/she will notify and direct the Contractor to correct the deficiency within a specified time. The specified time, which begins upon notification to the Contractor, will be from ½ hour to 24-hours based upon the urgency of the situation and the nature of the deficiency. The Engineer shall be the sole judge.

A deficiency may be the use of substandard devices, any lack of repair, maintenance, or non-compliance with the traffic control plan.

If the Contractor fails to correct a deficiency within the specified time, a daily monetary deduction will be imposed for each calendar day, or fraction thereof, that the deficiency exists. The calendar day(s) will begin with notification to the Contractor and end with the Engineer's acceptance of the correction. The daily monetary deduction will be \$250. If the Contractor fails to respond, the Engineer may correct the deficiency and the cost thereof will be deducted from monies due or which may become due to the Contractor. This corrective action will in no way relieve the Contractor of his/her contractual requirements or responsibilities.

TRAFFIC CONTROL PLAN (cont'd)

Basis of Payment:

The cost of the work stipulated within this Traffic Control Plan and the Traffic Control Standards along with the information signs and the labor, equipment and materials required to erect and remove said signs will not be paid for as a separate item, but the cost will be considered as included in the contract unit price for the construction items involved, and no additional compensation will be allowed.

HOT-MIX ASPHALT SURFACE REMOVAL

Description. This work shall consist of the partial removal of existing Hot-Mix Asphalt surfaces.

This work shall be in accordance with Article 440.04.

Construction Requirements. Any loose material shall be removed either by hand or with small equipment approved in advance by the Engineer. The Engineer will layout all butt joints to be completed.

The Contractor shall not be allowed to spread the grindings from the Hot-Mix Asphalt surface removal operations on the existing shoulders. The grindings shall be removed from the right-of-way.

Basis of Payment. This work will be paid for at the contract unit price per square yard for HOT-MIX ASPHALT SURFACE REMOVAL of the type or thickness specified.

MOBILIZATION

This contract contains no provisions for Mobilization. Therefore, Section 671 of the Standard Specifications is deleted.

SHORT TERM PAVEMENT MARKING

Work shall be in accordance with Article 703.05 **and** shall include removal of the temporary markings after the permanent markings are installed. The cost of removal shall be included in the cost of Short Term Pavement Marking.

ACORD CERTIFICATE OF LIABILITY INSURANCE OP ID ME ADAM003 DATE (MM/DD/YYYY) 01/08/19

PRODUCER River Valley Ins. Agency, Inc. 520 First Street LaSalle, IL 61301 Phone: 815-223-1505 Fax: 815-223-8890		THIS CERTIFICATE IS ISSUED AS A MATTER OF INFORMATION ONLY AND CONFERS NO RIGHTS UPON THE CERTIFICATE HOLDER. THIS CERTIFICATE DOES NOT AMEND, EXTEND OR ALTER THE COVERAGE AFFORDED BY THE POLICIES BELOW.	
INSURED Company Name/DBA MUST BE STATED XYZ General Contractors, Inc. 1234 Main St. Anytown IL 65432		INSURERS AFFORDING COVERAGE INSURER A: Five Star Speciality INSURER B: INSURER C: INSURER D: INSURER E:	NAIC #

SAMPLE

COVERAGES

THE POLICIES OF INSURANCE LISTED BELOW HAVE BEEN ISSUED TO THE INSURED NAMED ABOVE FOR THE POLICY PERIOD INDICATED. NOTWITHSTANDING ANY REQUIREMENT, TERM OR CONDITION OF ANY CONTRACT OR OTHER DOCUMENT WITH RESPECT TO WHICH THIS CERTIFICATE MAY BE ISSUED OR MAY PERTAIN, THE INSURANCE AFFORDED BY THE POLICIES DESCRIBED HEREIN IS SUBJECT TO ALL THE TERMS, EXCLUSIONS AND CONDITIONS OF SUCH POLICIES. AGGREGATE LIMITS SHOWN MAY HAVE BEEN REDUCED BY PAID CLAIMS.

INSR ADD'L LTR	INSRD	TYPE OF INSURANCE	POLICY NUMBER	POLICY EFFECTIVE DATE (MM/DD/YY)	POLICY EXPIRATION DATE (MM/DD/YY)	LIMITS
A	X	GENERAL LIABILITY <input checked="" type="checkbox"/> COMMERCIAL GENERAL LIABILITY <input type="checkbox"/> CLAIMS MADE <input checked="" type="checkbox"/> OCCUR GEN'L AGGREGATE LIMIT APPLIES PER: <input checked="" type="checkbox"/> POLICY <input type="checkbox"/> PRO-JECT <input type="checkbox"/> LOC	CWP 98999	01/07/19	01/07/20	EACH OCCURRENCE DAMAGE TO RENTED PREMISES (Ea occurrence) \$ \$1,000,000. MED EXP (Any one person) \$ PERSONAL & ADV INJURY \$ \$1,000,000. GENERAL AGGREGATE \$ \$2,000,000. PRODUCTS - COMP/OP AGG \$ \$2,000,000.
A	X	AUTOMOBILE LIABILITY <input type="checkbox"/> ANY AUTO <input checked="" type="checkbox"/> SCHEDULED AUTOS <input type="checkbox"/> HIRED AUTOS <input type="checkbox"/> NON-OWNED AUTOS	CA 98999	01/07/19	01/07/20	COMBINED SINGLE LIMIT (Ea accident) \$ \$1,000,000. BODILY INJURY (Per person) \$ BODILY INJURY (Per accident) \$ PROPERTY DAMAGE (Per accident) \$
		GARAGE LIABILITY <input type="checkbox"/> ANY AUTO				AUTO ONLY - EA ACCIDENT \$ OTHER THAN AUTO ONLY: EA ACC \$ AGG \$
A	X	EXCESS/UMBRELLA LIABILITY <input checked="" type="checkbox"/> OCCUR <input type="checkbox"/> CLAIMS MADE DEDUCTIBLE RETENTION \$	CX 98999	01/07/19	01/07/20	EACH OCCURRENCE \$ \$1,000,000. AGGREGATE \$ \$ \$
A		WORKERS COMPENSATION AND EMPLOYERS' LIABILITY ANY PROPRIETOR/PARTNER/EXECUTIVE OFFICER/MEMBER EXCLUDED? If yes, describe under SPECIAL PROVISIONS below	WCP 98999	01/07/19	01/07/20	WC STATUTORY LIMITS <input checked="" type="checkbox"/> OTHER E.L. EACH ACCIDENT \$ \$500,000. E.L. DISEASE - EA EMPLOYEE \$ \$500,000. E.L. DISEASE - POLICY LIMIT \$ \$500,000.
		OTHER				

DESCRIPTION OF OPERATIONS / LOCATIONS / VEHICLES / EXCLUSIONS ADDED BY ENDORSEMENT / SPECIAL PROVISIONS Section 23-00409-00-RS - County Highway 15
 It is understood and agreed - THE COUNTY OF LASALLE is "Additional Insured" on a Primary and Non-Contributory basis as pertains G.L., Auto & XS Libab. The Contractor & all Subcontractors waive subrogation for Workers Compensation.
 PLEASE NOTE - THIS CERTIFICATE IS FOR ILLUSTRATIVE PURPOSES ONLY AND CONVEYS NO COVERAGE OF ANY KIND **

CERTIFICATE HOLDER LASA004 County of LaSalle LaSalle County Highway Department 707 Etna Road Ottawa IL 61350		CANCELLATION SHOULD ANY OF THE ABOVE DESCRIBED POLICIES BE CANCELLED BEFORE THE EXPIRATION DATE THEREOF, THE ISSUING INSURER WILL ENDEAVOR TO MAIL 30 DAYS WRITTEN NOTICE TO THE CERTIFICATE HOLDER NAMED TO THE LEFT, BUT FAILURE TO DO SO SHALL IMPOSE NO OBLIGATION OR LIABILITY OF ANY KIND UPON THE INSURER, ITS AGENTS OR REPRESENTATIVES. AUTHORIZED REPRESENTATIVE Mike Nugent	
--	--	--	--

IMPORTANT

If the certificate holder is an ADDITIONAL INSURED, the policy(ies) must be endorsed. A statement on this certificate does not confer rights to the certificate holder in lieu of such endorsement(s).

If SUBROGATION IS WAIVED, subject to the terms and conditions of the policy, certain policies may require an endorsement. A statement on this certificate does not confer rights to the certificate holder in lieu of such endorsement(s).

DISCLAIMER

The Certificate of Insurance on the reverse side of this form does not constitute a contract between the issuing insurer(s), authorized representative or producer, and the certificate holder, nor does it affirmatively or negatively amend, extend or alter the coverage afforded by the policies listed thereon.

This listing of endorsements **MUST** accompany the Certificate of Liability Insurance

- GL additional Insured Endorsement
- GL additional Insured Endorsement to Include Primary and Non-Contributory
- GL additional Insured Endorsement to Include complete operations
- AL additional Insured Endorsement to Include Primary and Non-Contributory
- WC Waiver of Subrogation Endorsement

SEE SAMPLES – following pages

THIS ENDORSEMENT CHANGES THE POLICY. PLEASE READ IT CAREFULLY.

**ADDITIONAL INSURED – DESIGNATED
PERSON OR ORGANIZATION**

This endorsement modifies insurance provided under the following:

COMMERCIAL GENERAL LIABILITY COVERAGE PART

SCHEDULE

Name Of Additional Insured Person(s) Or Organization(s):

Sample

Information required to complete this Schedule, if not shown above, will be shown in the Declarations.

A. Section II – Who Is An Insured is amended to include as an additional insured the person(s) or organization(s) shown in the Schedule, but only with respect to liability for "bodily injury", "property damage" or "personal and advertising injury" caused, in whole or in part, by your acts or omissions or the acts or omissions of those acting on your behalf:

1. In the performance of your ongoing operations; or
2. In connection with your premises owned by or rented to you.

However:

1. The insurance afforded to such additional insured only applies to the extent permitted by law; and
2. If coverage provided to the additional insured is required by a contract or agreement, the insurance afforded to such additional insured will not be broader than that which you are required by the contract or agreement to provide for such additional insured.

B. With respect to the insurance afforded to these additional insureds, the following is added to Section III – Limits Of Insurance:

If coverage provided to the additional insured is required by a contract or agreement, the most we will pay on behalf of the additional insured is the amount of insurance:

1. Required by the contract or agreement; or
 2. Available under the applicable Limits of Insurance shown in the Declarations;
- whichever is less.

This endorsement shall not increase the applicable Limits of Insurance shown in the Declarations.

THIS ENDORSEMENT CHANGES THE POLICY. PLEASE READ IT CAREFULLY.

**ADDITIONAL INSURED – OWNERS, LESSEES OR
CONTRACTORS – SCHEDULED PERSON OR
ORGANIZATION**

This endorsement modifies insurance provided under the following:

COMMERCIAL GENERAL LIABILITY COVERAGE PART

SCHEDULE

Name Of Additional Insured Person(s) Or Organization(s)	Location(s) Of Covered Operations
Information required to complete this schedule, and which appears on the Declarations.	

A. Section II – Who Is An Insured – is amended to include as an additional insured the person(s) or organization(s) shown in the Schedule, but only with respect to liability for "bodily injury", "property damage" or "personal and advertising injury" caused, in whole or in part, by:

1. Your acts or omissions; or
2. The acts or omissions of those acting on your behalf;

in the performance of your ongoing operations for the additional insured(s) at the location(s) designated above.

However:

1. The insurance afforded to such additional insured only applies to the extent permitted by law; and
2. If coverage provided to the additional insured is required by a contract or agreement, the insurance afforded to such additional insured will not be broader than that which you are required by the contract or agreement to provide for such additional insured.

B. With respect to the insurance afforded to these additional insureds, the following additional exclusions apply:

This insurance does not apply to "bodily injury" or "property damage" occurring after:

1. All work, including materials, parts or equipment furnished in connection with such work, on the project (other than service, maintenance or repairs) to be performed by or on behalf of the additional insured(s) at the location of the covered operations has been completed; or
2. That portion of "your work" out of which the injury or damage arises has been put to its intended use by any person or organization other than another contractor or subcontractor engaged in performing operations for a principal as a part of the same project.

C. With respect to the insurance afforded to these additional insureds, the following is added to Section III - Limits of Insurance:

If coverage provided to the additional insured is required by a contract or agreement, the most we will pay on behalf of the additional insured is the amount of insurance:

1. Required by the contract or agreement; or

2. Available under the applicable limits of insurance shown in the Declarations;

whichever is less.

This endorsement shall not increase the applicable limits of insurance shown in the Declarations.

Sample

POLICY NUMBER:

COMMERCIAL GENERAL LIABILITY
CG 24 04 05 00

WAIVER OF TRANSFER OF RIGHTS OF RECOVERY AGAINST OTHERS TO US

This endorsement modifies insurance provided under the following:

COMMERCIAL GENERAL LIABILITY COVERAGE PART
PRODUCTS/COMPLETED OPERATIONS LIABILITY COVERAGE PART

SCHEDULE

Name Of Person Or Organization:

Information required to complete this Schedule, if not shown above, will be shown in the Declarations.

The following is added to Paragraph 8, Transfer Of Rights Of Recovery Against Others To Us of Section IV - Conditions:

We waive any right of recovery we may have against the person or organization shown in the Schedule above because of payments we make or for liability damage arising from your ongoing operations or "your work" done under a contract with that person or organization and included in the products-completed operations hazard. This waiver applies only to the person or organization shown in the Schedule above.

Sample

THIS ENDORSEMENT CHANGES THE POLICY. PLEASE READ IT CAREFULLY.

**ADDITIONAL INSURED – OWNERS, LESSEES OR
CONTRACTORS – COMPLETED OPERATIONS**

This endorsement modifies insurance provided under the following:

COMMERCIAL GENERAL LIABILITY COVERAGE PART
PRODUCTS/COMPLETED OPERATIONS LIABILITY COVERAGE PART

SCHEDULE

Name Of Additional Insured Person(s) Or Organization(s)	Location And Description Of Completed Operations
<h1>Sample</h1>	
Information required to complete this Schedule, if not shown above, will be shown in the Declarations.	

A. Section II – Who Is An Insured is amended to include as an additional insured the person(s) or organization(s) shown in the Schedule, but only with respect to liability for "bodily injury" or "property damage" caused, in whole or in part, by "your work" at the location designated and described in the Schedule of this endorsement performed for that additional insured and included in the "products-completed operations hazard".

However:

1. The insurance afforded to such additional insured only applies to the extent permitted by law; and
2. If coverage provided to the additional insured is required by a contract or agreement, the insurance afforded to such additional insured will not be broader than that which you are required by the contract or agreement to provide for such additional insured.

B. With respect to the insurance afforded to these additional insureds, the following is added to Section III – Limits Of Insurance:

If coverage provided to the additional insured is required by a contract or agreement, the most we will pay on behalf of the additional insured is the amount of insurance:

1. Required by the contract or agreement; or
2. Available under the applicable Limits of Insurance shown in the Declarations;

whichever is less.

This endorsement shall not increase the applicable Limits of insurance shown in the Declarations.

THIS ENDORSEMENT CHANGES THE POLICY. PLEASE READ IT CAREFULLY.

DESIGNATED INSURED – PRIMARY NON-CONTRIBUTORY COVERAGE WHEN REQUIRED BY INSURED CONTRACT OR CERTIFICATE

This endorsement modified insurance provided under the
BUSINESS AUTO COVERAGE FORM

The provisions of the Coverage Form apply unless changed by this endorsement.

This endorsement identifies person(s) or organization(s) who are "insured" under the Who Is An Insured Provision of the Coverage Form.

This endorsement changes the policy on the inception date of the policy, unless another date is shown below.

Endorsement Effective:

Named Insured:

Section II – Liability Coverage. A. Coverage, 1. Who Is An Insured is amended to add:

Any person or organization with whom you have an "insured contract" which requires:

- I. That person or organization to be added as an "insured" under this policy or on a certificate of insurance; and
- II. This policy to be primary and non-contributory to any like insurance available to the person or organization.

Each such person or organization is an "insured" for liability coverage. They are an "insured" only if that person or organization is an "insured" under SECTION II of the Coverage Form.

The contract between the Named Insured and the person or organization is an "insured contract".

Section IV – Business Auto Conditions. B. General Conditions, 5. Other Insurance. Paragraph d. is deleted and replaced by the following for the purpose of this endorsement only:

- d. When coverage provided under this Coverage Form is also provided under another Coverage Form or policy, we will provide coverage on a primary, non-contributory basis.

WAIVER OF OUR RIGHT TO RECOVER FROM OTHERS ENDORSEMENT

We have the right to recover our payments from anyone liable for an injury covered by this policy. We will not enforce our right against the person or organization named in the Schedule. (This agreement applies only to the extent that you perform work under a written contract that requires you to obtain this agreement from us.)

This agreement shall not operate directly or indirectly to benefit anyone not named in the Schedule.

Schedule

Sample

This endorsement changes the policy to which it is attached and is effective on the date issued unless otherwise stated.

(The information below is required only when this endorsement is issued subsequent to preparation of the policy.)

Endorsement Issued	Effective Policy No.	Endorsement No. Premium
Insurance Company	Countersigned by _____	

State of Illinois
Department of Transportation
Bureau of Local Roads and Streets
SPECIAL PROVISION
FOR
CONSTRUCTION AND MAINTENANCE SIGNS

Effective: January 1, 2004
Revised: June 1, 2007

All references to Sections or Articles in this specification shall be construed to mean a specific Section or Article of the Standard Specifications for Road and Bridge Construction, adopted by the Department of Transportation.

701.14. Signs. Add the following paragraph to Article 701.14:

All warning signs shall have minimum dimensions of 1200 mm x 1200 mm (48" x 48") and have a black legend on a fluorescent orange reflectorized background, meeting, as a minimum, Type AP reflectivity requirements of Table 1091-2 in Article 1091.02.

State of Illinois
DEPARTMENT OF TRANSPORTATION
Bureau of Local Roads & Streets

SPECIAL PROVISION
FOR
GROWTH CURVE

Effective: March 1, 2008
Revised: December 13, 2021

All references to Sections and Articles in this Special Provision shall be construed to mean specific Sections and Articles in the Standard Specifications for Road and Bridge Construction adopted by the Department of Transportation.

The Contractor shall perform a growth curve at the beginning of placement of each type of mix and each lift. The growth curve for each type of mix and each lift shall be performed within the first 200 tons (180 metric tons). If an adjustment is made to the specific mix design, the Engineer reserves the right to request an additional growth curve and supporting tests at the Contractor's expense.

Compaction of the growth curve shall commence immediately after the course is placed and at a temperature of not less than 280 °F (140 °C). The growth curve, consisting of a plot of lb/cu ft (kg/cu m) vs. number of passes with the project breakdown roller, shall be developed. Roller speed during the growth curve testing shall be the same as the normal paving operation. This curve shall be established by use of a nuclear gauge. Tests shall be taken after each pass until the highest lb/cu ft (kg/cu m) is obtained. This value shall be the target density provided the HMA Gyratory air voids are within acceptable limits. If the HMA Gyratory air voids are not within the specified limits, corrective action shall be taken, and a new target density shall be established.

A new growth curve is required if the breakdown roller used on the growth curve is replaced with a new roller during production. The target density shall apply only to the specific gauge used. If additional gauges are to be used to determine density specification compliance, the Contractor shall establish a unique minimum allowable target density from the growth curve location for each gauge.

At least one core sample per day shall be taken at a location specified by the Engineer. Core densities will be determined using the Illinois-Modified AASHTO T 166 or T 275 procedure by the Department. The core density shall be according to Articles 1030.09(c). Any required corrective action for testing using nuclear density testing shall be according to Article 1030.09(f). The QA Manager is responsible for assuring and documenting that the determined number of rollerpasses has been accomplished. The Engineer reserves the right to take core samples at any time to verify density from the nuclear gauge.

All lifts and confined longitudinal joint edges shall be compacted to an average nuclear gauge density of not less than 95 percent nor greater than 102 percent of the target density obtained on the growth curve. Unconfined longitudinal joint edges shall be compacted to an average nuclear gauge density of not less than 93 percent nor greater than 102 percent of the target density obtained on the growth curve. The average nuclear gauge density shall be based on tests representing one day's production.

Quality Control density tests shall be performed at randomly selected locations within 1/2 mile (800 m) intervals per lift per lane. In no case shall more than one half day's production be completed without density testing being performed. Longitudinal joint density testing shall be performed at each random density test location. Longitudinal joint testing shall be located at a distance equal to the lift thickness or a minimum of 2 in. (50 mm) from each pavement edge.

If the Contractor is not controlling the compaction process and is making no effort to take corrective action, the operation shall stop as directed by the Engineer.

CEMENT, TYPE IL (BDE)

Effective: August 1, 2023

Add the following to Article 302.02 of the Standard Specifications:

“(k) Type IL Portland-Limestone Cement1001”

Revise Note 2 of Article 352.02 of the Standard Specifications to read:

“Note 2. Either Type I or Type IA portland cement or Type IL portland-limestone cement shall be used.”

Revise Note 1 of Article 404.02 of the Standard Specifications to read:

“Note 1. The cement shall be Type I portland cement or Type IL portland-limestone cement.”

Revise Article 1019.02(a) of the Standard Specifications to read:

“(a) Cement, Type I or IL1001”

80449

COMPENSABLE DELAY COSTS (BDE)

Effective: June 2, 2017

Revised: April 1, 2019

Revise Article 107.40(b) of the Standard Specifications to read:

“(b) Compensation. Compensation will not be allowed for delays, inconveniences, or damages sustained by the Contractor from conflicts with facilities not meeting the above definition; or if a conflict with a utility in an unanticipated location does not cause a shutdown of the work or a documentable reduction in the rate of progress exceeding the limits set herein. The provisions of Article 104.03 notwithstanding, compensation for delays caused by a utility in an unanticipated location will be paid according to the provisions of this Article governing minor and major delays or reduced rate of production which are defined as follows.

- (1) Minor Delay. A minor delay occurs when the work in conflict with the utility in an unanticipated location is completely stopped for more than two hours, but not to exceed two weeks.
- (2) Major Delay. A major delay occurs when the work in conflict with the utility in an unanticipated location is completely stopped for more than two weeks.
- (3) Reduced Rate of Production Delay. A reduced rate of production delay occurs when the rate of production on the work in conflict with the utility in an unanticipated location decreases by more than 25 percent and lasts longer than seven calendar days.”

Revise Article 107.40(c) of the Standard Specifications to read:

“(c) Payment. Payment for Minor, Major, and Reduced Rate of Production Delays will be made as follows.

- (1) Minor Delay. Labor idled which cannot be used on other work will be paid for according to Article 109.04(b)(1) and (2) for the time between start of the delay and the minimum remaining hours in the work shift required by the prevailing practice in the area.

Equipment idled which cannot be used on other work, and which is authorized to standby on the project site by the Engineer, will be paid for according to Article 109.04(b)(4).

- (2) Major Delay. Labor will be the same as for a minor delay.

Equipment will be the same as for a minor delay, except Contractor-owned equipment will be limited to two weeks plus the cost of move-out to either the

Contractor's yard or another job and the cost to re-mobilize, whichever is less. Rental equipment may be paid for longer than two weeks provided the Contractor presents adequate support to the Department (including lease agreement) to show retaining equipment on the job is the most economical course to follow and in the public interest.

- (3) Reduced Rate of Production Delay. The Contractor will be compensated for the reduced productivity for labor and equipment time in excess of the 25 percent threshold for that portion of the delay in excess of seven calendar days. Determination of compensation will be in accordance with Article 104.02, except labor and material additives will not be permitted.

Payment for escalated material costs, escalated labor costs, extended project overhead, and extended traffic control will be determined according to Article 109.13."

Revise Article 108.04(b) of the Standard Specifications to read:

"(b) No working day will be charged under the following conditions.

- (1) When adverse weather prevents work on the controlling item.
- (2) When job conditions due to recent weather prevent work on the controlling item.
- (3) When conduct or lack of conduct by the Department or its consultants, representatives, officers, agents, or employees; delay by the Department in making the site available; or delay in furnishing any items required to be furnished to the Contractor by the Department prevents work on the controlling item.
- (4) When delays caused by utility or railroad adjustments prevent work on the controlling item.
- (5) When strikes, lock-outs, extraordinary delays in transportation, or inability to procure critical materials prevent work on the controlling item, as long as these delays are not due to any fault of the Contractor.
- (6) When any condition over which the Contractor has no control prevents work on the controlling item."

Revise Article 109.09(f) of the Standard Specifications to read:

"(f) Basis of Payment. After resolution of a claim in favor of the Contractor, any adjustment in time required for the work will be made according to Section 108. Any adjustment in the costs to be paid will be made for direct labor, direct materials, direct equipment, direct jobsite overhead, direct offsite overhead, and other direct costs allowed by the resolution. Adjustments in costs will not be made for interest charges, loss of anticipated profit, undocumented loss of efficiency, home office overhead and unabsorbed overhead

other than as allowed by Article 109.13, lost opportunity, preparation of claim expenses and other consequential indirect costs regardless of method of calculation.

The above Basis of Payment is an essential element of the contract and the claim cost recovery of the Contractor shall be so limited.”

Add the following to Section 109 of the Standard Specifications.

“109.13 Payment for Contract Delay. Compensation for escalated material costs, escalated labor costs, extended project overhead, and extended traffic control will be allowed when such costs result from a delay meeting the criteria in the following table.

Contract Type	Cause of Delay	Length of Delay
Working Days	Article 108.04(b)(3) or Article 108.04(b)(4)	No working days have been charged for two consecutive weeks.
Completion Date	Article 108.08(b)(1) or Article 108.08(b)(7)	The Contractor has been granted a minimum two week extension of contract time, according to Article 108.08.

Payment for each of the various costs will be according to the following.

- (a) Escalated Material and/or Labor Costs. When the delay causes work, which would have otherwise been completed, to be done after material and/or labor costs have increased, such increases will be paid. Payment for escalated material costs will be limited to the increased costs substantiated by documentation furnished by the Contractor. Payment for escalated labor costs will be limited to those items in Article 109.04(b)(1) and (2), except the 35 percent and 10 percent additives will not be permitted.
- (b) Extended Project Overhead. For the duration of the delay, payment for extended project overhead will be paid as follows.
 - (1) Direct Jobsite and Offsite Overhead. Payment for documented direct jobsite overhead and documented direct offsite overhead, including onsite supervisory and administrative personnel, will be allowed according to the following table.

Original Contract Amount	Supervisory and Administrative Personnel
Up to \$5,000,000	One Project Superintendent
Over \$ 5,000,000 - up to \$25,000,000	One Project Manager, One Project Superintendent or Engineer, and One Clerk
Over \$25,000,000 - up to \$50,000,000	One Project Manager, One Project Superintendent, One Engineer, and

	One Clerk
Over \$50,000,000	One Project Manager, Two Project Superintendents, One Engineer, and One Clerk

(2) Home Office and Unabsorbed Overhead. Payment for home office and unabsorbed overhead will be calculated as 8 percent of the total delay cost.

(c) Extended Traffic Control. Traffic control required for an extended period of time due to the delay will be paid for according to Article 109.04.

When an extended traffic control adjustment is paid under this provision, an adjusted unit price as provided for in Article 701.20(a) for increase or decrease in the value of work by more than ten percent will not be paid.

Upon payment for a contract delay under this provision, the Contractor shall assign subrogation rights to the Department for the Department's efforts of recovery from any other party for monies paid by the Department as a result of any claim under this provision. The Contractor shall fully cooperate with the Department in its efforts to recover from another party any money paid to the Contractor for delay damages under this provision."

HOT-MIX ASPHALT (BDE)

Effective: January 1, 2024

Revise the second paragraph of Articles 1030.07(a)(11) and 1030.08(a)(9) of the Standard Specifications to read:

“When establishing the target density, the HMA maximum theoretical specific gravity (G_{mm}) will be based on the running average of four available Department test results for that project. If less than four G_{mm} test results are available, an average of all available Department test results for that project will be used. The initial G_{mm} will be the last available Department test result from a QMP project. If there is no available Department test result from a QMP project, the Department mix design verification test result will be used as the initial G_{mm} .”

In the Supplemental Specifications, replace the revision for the end of the third paragraph of Article 1030.09(h)(2) with the following:

“When establishing the target density, the HMA maximum theoretical specific gravity (G_{mm}) will be the Department mix design verification test result.”

Revise the tenth paragraph of Article 1030.10 of the Standard Specifications to read:

“Production is not required to stop after a test strip has been constructed.”

80456

HOT-MIX ASPHALT – LONGITUDINAL JOINT SEALANT (BDE)

Effective: November 1, 2022

Revised: August 1, 2023

Add the following after the second sentence in the eighth paragraph of Article 406.06(h)(2) of the Standard Specifications:

“If rain is forecasted and traffic is to be on the LJS or if pickup/tracking of the LJS material is likely, the LJS shall be covered immediately following its application with FA 20 fine aggregate mechanically spread uniformly at a rate of 1.5 ± 0.5 lb/sq yd (0.75 ± 0.25 kg/sq m). Fine aggregate landing outside of the LJS shall be removed prior to application of tack coat.”

Add the following after the first sentence in the ninth paragraph of Article 406.06(h)(2) of the Standard Specifications:

“LJS half-width shall be applied at a width of 9 ± 1 in. (225 ± 25 mm) in the immediate lane to be placed with the outside edge flush with the joint of the next HMA lift. The vertical face of any longitudinal joint remaining in place shall also be coated.”

Add the following after the eleventh paragraph of Article 406.06(h)(2) of the Standard Specifications:

“LJS Half-Width Application Rate, lb/ft (kg/m) ^{1/}			
Lift Thickness, in. (mm)	Coarse Graded Mixture (IL-19.0, IL-19.0L, IL-9.5, IL-9.5L, IL-4.75)	Fine Graded Mixture (IL-9.5FG)	SMA Mixture (SMA-9.5, SMA-12.5)
$\frac{3}{4}$ (19)	0.44 (0.66)		
1 (25)	0.58 (0.86)		
$1 \frac{1}{4}$ (32)	0.66 (0.98)	0.44 (0.66)	
$1 \frac{1}{2}$ (38)	0.74 (1.10)	0.48 (0.71)	0.63 (0.94)
$1 \frac{3}{4}$ (44)	0.82 (1.22)	0.52 (0.77)	0.69 (1.03)
2 (50)	0.90 (1.34)	0.56 (0.83)	0.76 (1.13)
$\geq 2 \frac{1}{4}$ (60)	0.98 (1.46)		

1/ The application rate includes a surface demand for liquid. The thickness of the LJS may taper from the center of the application to a lesser thickness on the edge of the application, provided the correct width and application rate are maintained.”

Revise the second paragraph of Article 406.13(b) of the Standard Specifications to read:

“Aggregate for covering tack, LJS, or FLS will not be measured for payment.”

Add the following to the end of the second paragraph of Article 406.14 of the Standard Specifications:

“Longitudinal joint sealant (LJS) half-width will be paid for at the contract unit price per foot (meter) for LONGITUDINAL JOINT SEALANT, HALF-WIDTH.”

80446

REMOVAL AND DISPOSAL OF REGULATED SUBSTANCES (BDE)

Effective: January 1, 2024

Revised: April 1, 2024

Revise the first paragraph of Article 669.04 of the Standard Specifications to read:

“669.04 Regulated Substances Monitoring. Regulated substances monitoring includes environmental observation and field screening during regulated substances management activities. The excavated soil and groundwater within the work areas shall be managed as either uncontaminated soil, hazardous waste, special waste, or non-special waste.

As part of the regulated substances monitoring, the monitoring personnel shall perform and document the applicable duties listed on form BDE 2732 “Regulated Substances Monitoring Daily Record (RSMDR)”.

Revise the first two sentences of the nineteenth paragraph of Article 669.05 of the Standard Specifications to read:

“The Contractor shall coordinate waste disposal approvals with the disposal facility and provide the specific analytical testing requirements of that facility. The Contractor shall make all arrangements for collection, transportation, and analysis of landfill acceptance testing.”

Revise the last paragraph of Article 669.05 of the Standard Specifications to read:

“The Contractor shall select a permitted landfill facility or CCDD/USFO facility meeting the requirements of 35 Ill. Admin. Code Parts 810-814 or Part 1100, respectively. The Department will review and approve or reject the facility proposed by the Contractor based upon information provided in BDE 2730. The Contractor shall verify whether the selected facility is compliant with those applicable standards as mandated by their permit and whether the facility is presently, has previously been, or has never been, on the United States Environmental Protection Agency (U.S. EPA) National Priorities List or the Resource Conservation and Recovery Act (RCRA) List of Violating Facilities. The use of a Contractor selected facility shall in no manner delay the construction schedule or alter the Contractor's responsibilities as set forth.”

Revise the first paragraph of Article 669.07 of the Standard Specifications to read:

“669.07 Temporary Staging. Soil classified according to Articles 669.05(a)(2), (b)(1), or (c) may be temporarily staged at the Contractor's option. All other soil classified according to Articles 669.05(a)(1), (a)(3), (a)(4), (a)(5), (a)(6), or (b)(2) shall be managed and disposed of without temporary staging to the greatest extent practicable. If circumstances beyond the Contractor's control require temporary staging of these latter materials, the Contractor shall request approval from the Engineer in writing.

Topsoil for re-use as final cover which has been field screened and found not to exhibit PID readings over daily background readings as documented on the BDE 2732, visual staining or

odors, and is classified according to Articles 669.05(a)(2), (a)(3), (a)(4), (b)(1), or (c) may be temporarily staged at the Contractor's option."

Add the following paragraph after the sixth paragraph of Article 669.11 of the Standard Specifications.

"The sampling and testing of effluent water derived from dewatering discharges for priority pollutants volatile organic compounds (VOCs), priority pollutants semi-volatile organic compounds (SVOCs), or priority pollutants metals, will be paid for at the contract unit price per each for VOCS GROUNDWATER ANALYSIS using EPA Method 8260B, SVOCs GROUNDWATER ANALYSIS using EPA Method 8270C, or RCRA METALS GROUNDWATER ANALYSIS using EPA Methods 6010B and 7471A. This price shall include transporting the sample from the job site to the laboratory."

Revise the first sentence of the eight paragraph of Article 669.11 of the Standard Specifications to read:

"Payment for temporary staging of soil classified according to Articles 669.05(a)(1), (a)(3), (a)(4), (a)(5), (a)(6), or (b)(2) to be managed and disposed of, if required and approved by the Engineer, will be paid according to Article 109.04."

80455

SHORT TERM AND TEMPORARY PAVEMENT MARKINGS (BDE)

Effective: April 1, 2024
Revised: April 2, 2024

Revise Article 701.02(d) of the Standard Specifications to read:

“(d) Pavement Marking Tapes (Note 3) 1095.06”

Add the following Note to the end of Article 701.02 of the Standard Specifications:

“Note 3. White or yellow pavement marking tape that is to remain in place longer than 14 days shall be Type IV tape.”

Revise Article 703.02(c) of the Standard Specifications to read:

“(c) Pavement Marking Tapes (Note 1) 1095.06”

Add the following Note to the end of Article 703.02 of the Standard Specifications:

“Note 1. White or yellow pavement marking tape that is to remain in place longer than 14 days shall be Type IV tape.”

Revise Article 1095.06 of the Standard Specifications to read:

“1095.06 Pavement Marking Tapes. Type I white or yellow marking tape shall consist of glass spheres embedded into a binder on a foil backing that is precoated with a pressure sensitive adhesive. The spheres shall be of uniform gradation and distributed evenly over the surface of the tape.

Type IV tape shall consist of white or yellow tape with wet reflective media incorporated to provide immediate and continuing retroreflection in wet and dry conditions. The wet retroreflective media shall be bonded to a durable polyurethane surface. The patterned surface shall have approximately 40 ± 10 percent of the surface area raised and presenting a near vertical face to traffic from any direction. The channels between the raised areas shall be substantially free of exposed reflective elements or particles.

Blackout tape shall consist of a matte black, non-reflective, patterned surface that is precoated with a pressure sensitive adhesive.

- (a) Color. The white and yellow markings shall meet the following requirements for daylight reflectance and color, when tested, using a color spectrophotometer with 45 degrees circumferential/zero degree geometry, illuminant D65, and two degree observer angle. The color instrument shall measure the visible spectrum from 380 to 720 nm with a wavelength measurement interval and spectral bandpass of 10 nm.

Color	Daylight Reflectance %Y
White	65 min.
Yellow *	36 - 59

*Shall match Aerospace Material Specification Standard 595 33538 (Orange Yellow) and the chromaticity limits as follows.

x	0.490	0.475	0.485	0.530
y	0.470	0.438	0.425	0.456

- (b) Retroreflectivity. The white and yellow markings shall be retroreflective. Reflective values measured in accordance with the photometric testing procedure of ASTM D 4061 shall not be less than those listed in the table below. The coefficient of retroreflected luminance, R_L , shall be expressed as average millicandelas/footcandle/sq ft (millicandelas/lux/sq m), measured on a 3.0 x 0.5 ft (900 mm x 150 mm) panel at 86 degree entrance angle.

Coefficient of Retroreflected Luminance, R_L , Dry					
Type I			Type IV		
Observation Angle	White	Yellow	Observation Angle	White	Yellow
0.2°	2700	2400	0.2°	1300	1200
0.5°	2250	2000	0.5°	1100	1000

Wet retroreflectance shall be measured for Type IV under wet conditions according to ASTM E 2177 and meet the following.

Wet Retroreflectance, Initial R_L	
Color	R_L 1.05/88.76
White	300
Yellow	200

- (c) Skid Resistance. The surface of Type IV and blackout markings shall provide a minimum skid resistance of 45 BPN when tested according to ASTM E 303.
- (d) Application. The pavement marking tape shall have a precoated pressure sensitive adhesive and shall require no activation procedures. Test pieces of the tape shall be applied according to the manufacturer's instructions and tested according to ASTM D 1000, Method A, except that a stiff, short bristle roller brush and heavy hand pressure will be substituted for the weighted rubber roller in applying the test pieces to the metal test panel. Material tested as directed above shall show a minimum adhesion value of 750 g/in. (30 g/mm) width at the temperatures specified in ASTM D 1000. The adhesive shall be resistant to oils, acids, solvents, and water, and shall not leave objectionable stains or residue after removal. The material shall be flexible and conformable to the texture of the pavement.

(e) Durability. Type IV and blackout tape shall be capable of performing for the duration of a normal construction season and shall then be capable of being removed intact or in large sections at pavement temperatures above 40 °F (4 °C) either manually or with a roll-up device without the use of sandblasting, solvents, or grinding. The Contractor shall provide a manufacturer's certification that the material meets the requirements for being removed after the following minimum traffic exposure based on transverse test decks with rolling traffic.

- (1) Time in place - 400 days
- (2) ADT per lane - 9,000 (28 percent trucks)
- (3) Axle hits - 10,000,000 minimum

Samples of the material applied to standard specimen plates will be measured for thickness and tested for durability in accordance with ASTM D 4060, using a CS-17 wheel and 1000-gram load, and shall meet the following criteria showing no significant change in color after being tested for the number of cycles indicated.

Test	Type I	Type IV	Blackout
Minimum Initial Thickness, mils (mm)	20 (0.51)	65 (1.65) ^{1/} 20 (0.51) ^{2/}	65 (1.65) ^{1/} 20 (0.51) ^{2/}
Durability (cycles)	5,000	1,500	1,500

1/ Measured at the thickest point of the patterned surface.

2/ Measured at the thinnest point of the patterned surface.

The pavement marking tape, when applied according to the manufacturer's recommended procedures, shall be weather resistant and shall show no appreciable fading, lifting, or shrinkage during the useful life of the marking. The tape, as applied, shall be of good appearance, free of cracks, and edges shall be true, straight, and unbroken.

(f) Sampling and Inspection.

(1) Sample. Prior to approval and use of Type IV pavement marking tape, the manufacturer shall submit a notarized certification from an independent laboratory, together with the results of all tests, stating that the material meets the requirements as set forth herein. The independent laboratory test report shall state the lot tested, the manufacturer's name, and the date of manufacture.

After initial approval by the Department, samples and certification by the manufacturer shall be submitted for each subsequent batch of Type IV tape used. The manufacturer shall submit a certification stating that the material meets the requirements as set forth herein and is essentially identical to the material sent for qualification. The certification shall state the lot tested, the manufacturer's name, and the date of manufacture.

- (2) Inspection. The Contractor shall provide a manufacturer's certification to the Engineer stating the material meets all requirements of this specification. All material samples for acceptance tests shall be taken or witnessed by a representative of the Bureau of Materials and shall be submitted to the Engineer of Materials, 126 East Ash Street, Springfield, Illinois 62704-4766 at least 30 days in advance of the pavement marking operations."

80457

VEHICLE AND EQUIPMENT WARNING LIGHTS (BDE)

Effective: November 1, 2021

Revised: November 1, 2022

Add the following paragraph after the first paragraph of Article 701.08 of the Standard Specifications:

“The Contractor shall equip all vehicles and equipment with high-intensity oscillating, rotating, or flashing, amber or amber-and-white, warning lights which are visible from all directions. In accordance with 625 ILCS 5/12-215, the lights may only be in operation while the vehicle or equipment is engaged in construction operations.”

80439

WORK ZONE TRAFFIC CONTROL DEVICES (BDE)

Effective: March 2, 2020

Add the following to Article 701.03 of the Standard Specifications:

“(q) Temporary Sign Supports 1106.02”

Revise the third paragraph of Article 701.14 of the Standard Specifications to read:

“For temporary sign supports, the Contractor shall provide a FHWA eligibility letter for each device used on the contract. The letter shall provide information for the set-up and use of the device as well as a detailed drawing of the device. The signs shall be supported within 20 degrees of vertical. Weights used to stabilize signs shall be attached to the sign support per the manufacturer’s specifications.”

Revise the first paragraph of Article 701.15 of the Standard Specifications to read:

“**701.15 Traffic Control Devices.** For devices that must meet crashworthiness standards, the Contractor shall provide a manufacturer’s self-certification or a FHWA eligibility letter for each Category 1 device and a FHWA eligibility letter for each Category 2 and Category 3 device used on the contract. The self-certification or letter shall provide information for the set-up and use of the device as well as a detailed drawing of the device.”

Revise the first six paragraphs of Article 1106.02 of the Standard Specifications to read:

“**1106.02 Devices.** Work zone traffic control devices and combinations of devices shall meet crashworthiness standards for their respective categories. The categories are as follows.

Category 1 includes small, lightweight, channelizing and delineating devices that have been in common use for many years and are known to be crashworthy by crash testing of similar devices or years of demonstrable safe performance. These include cones, tubular markers, plastic drums, and delineators, with no attachments (e.g. lights). Category 1 devices manufactured after December 31, 2019 shall be MASH-16 compliant. Category 1 devices manufactured on or before December 31, 2019, and compliant with NCHRP 350 or MASH 2009, may be used on contracts let before December 31, 2024.

Category 2 includes devices that are not expected to produce significant vehicular velocity change but may otherwise be hazardous. These include vertical panels with lights, barricades, temporary sign supports, and Category 1 devices with attachments (e.g. drums with lights). Category 2 devices manufactured after December 31, 2019 shall be MASH-16 compliant. Category 2 devices manufactured on or before December 31, 2019, and compliant with NCHRP 350 or MASH 2009, may be used on contracts let before December 31, 2024.

Category 3 includes devices that are expected to cause significant velocity changes or other potentially harmful reactions to impacting vehicles. These include crash cushions (impact

attenuators), truck mounted attenuators, and other devices not meeting the definitions of Category 1 or 2. Category 3 devices manufactured after December 31, 2019 shall be MASH-16 compliant. Category 3 devices manufactured on or before December 31, 2019, and compliant with NCHRP 350 or MASH 2009, may be used on contracts let before December 31, 2029. Category 3 devices shall be crash tested for Test Level 3 or the test level specified.

Category 4 includes portable or trailer-mounted devices such as arrow boards, changeable message signs, temporary traffic signals, and area lighting supports. It is preferable for Category 4 devices manufactured after December 31, 2019 to be MASH-16 compliant; however, there are currently no crash tested devices in this category, so it remains exempt from the NCHRP 350 or MASH compliance requirement.

For each type of device, when no more than one MASH-16 compliant is available, an NCHRP 350 or MASH-2009 compliant device may be used, even if manufactured after December 31, 2019.”

Revise Articles 1106.02(g), 1106.02(k), and 1106.02(l) to read:

“(g) Truck Mounted/Trailer Mounted Attenuators. The attenuator shall be approved for use at Test Level 3. Test Level 2 may be used for normal posted speeds less than or equal to 45 mph.

(k) Temporary Water Filled Barrier. The water filled barrier shall be a lightweight plastic shell designed to accept water ballast and be on the Department’s qualified product list.

Shop drawings shall be furnished by the manufacturer and shall indicate the deflection of the barrier as determined by acceptance testing; the configuration of the barrier in that test; and the vehicle weight, velocity, and angle of impact of the deflection test. The Engineer shall be provided one copy of the shop drawings.

(l) Movable Traffic Barrier. The movable traffic barrier shall be on the Department’s qualified product list.

Shop drawings shall be furnished by the manufacturer and shall indicate the deflection of the barrier as determined by acceptance testing; the configuration of the barrier in that test; and the vehicle weight, velocity, and angle of impact of the deflection test. The Engineer shall be provided one copy of the shop drawings. The barrier shall be capable of being moved on and off the roadway on a daily basis.”

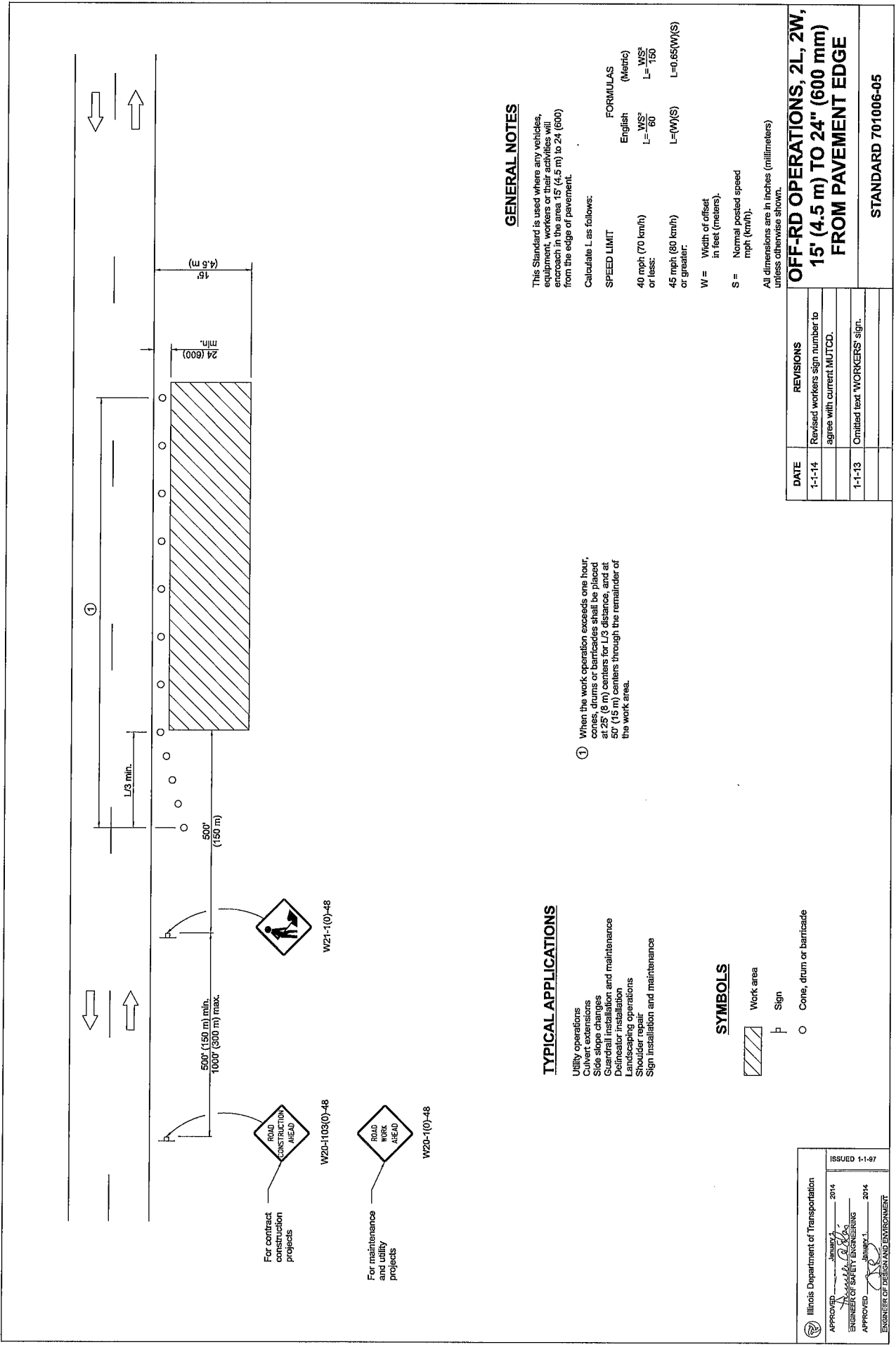

For contract construction projects

For maintenance and utility projects

W21-1(0)-48

W20-1102(O)-48

W20-1(0)-48

TYPICAL APPLICATIONS

- Utility operations
- Culvert expansions
- Side slope changes
- Guardrail installation and maintenance
- Delineator installation
- Landscaping operations
- Shoulder repair
- Sign installation and maintenance

SYMBOLS

- Work area
- Sign
- Cone, drum or barricade

① When the work operation exceeds one hour, cones, drums or barricades shall be placed at 25' (8 m) centers for L/3 distance, and at 50' (15 m) centers through the remainder of the work area.

GENERAL NOTES

This Standard is used where any vehicles, equipment, workers or their activities will encroach in the area 15' (4.5 m) to 24' (600) from the edge of pavement.

Calculate L as follows:

SPEED LIMIT

40 mph (70 km/h) or less: $L = \frac{WS^2}{60}$

45 mph (80 km/h) or greater: $L = (W)(S)$

W = Width of offset in feet (meters).

S = Normal posted speed mph (km/h).

All dimensions are in inches (millimeters) unless otherwise shown.

FORMULAS

English (Metric)

$L = \frac{WS^2}{60}$ (Metric)

$L = (W)(S)$ (Metric)

DATE	REVISIONS
1-1-14	Revised workers sign number to agree with current MUTCD.
1-1-13	Omitted text 'WORKERS' sign.

OFF-RD OPERATIONS, 2L, 2W, 15' (4.5 m) TO 24" (600 mm) FROM PAVEMENT EDGE

STANDARD 701006-05

Illinois Department of Transportation

ISSUED 1-1-07

APPROVED: [Signature] 2014
 ENGINEER OF SAFETY ENGINEERING

APPROVED: [Signature] 2014
 ENGINEER OF DESIGN AND ENVIRONMENT

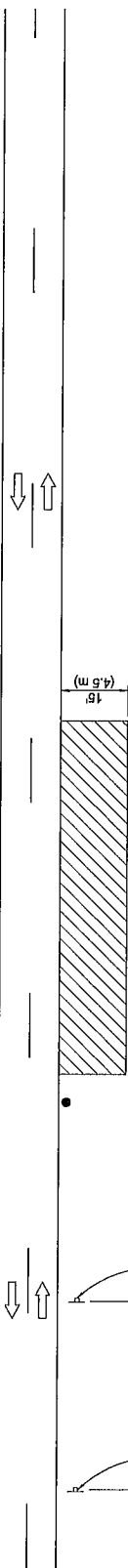
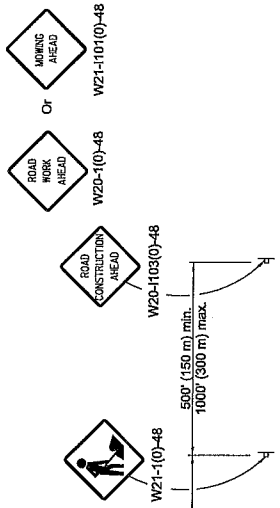

For contract construction projects

For maintenance and utility projects

TYPICAL APPLICATIONS

Shoulder work
Utility operations

GENERAL NOTES

This Standard is used where at any time, any vehicle, equipment, workers or their activities are engaged in any type of mowing operation on the shoulder, where the average speed is 1 mph (2 km/h) or less.

When the work operation does not exceed 60 minutes, traffic control may be according to Standard 701301.

All dimensions are in inches (millimeters) unless otherwise shown.

- ① Minimum distance is 200' (60 m). Maximum distance to be determined by the Engineer but should not exceed 1/3 the length required for one normal working day's operation, or 4 miles (6.4 km) whichever is less.

SYMBOLS

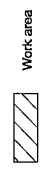

Sign

● Flagger with traffic control sign when required

DATE	REVISIONS
1-1-14	Revised workers sign number to agree with current MUTCD.
1-1-13	Omitted text "WORKERS" sign.

OFF-RD MOVING OPERATIONS 2L, 2W, DAY ONLY

STANDARD 701011-04

Illinois Department of Transportation

APPROVED *[Signature]* January 1, 2014
ENGINEER OF SAFETY ENGINEERING

APPROVED *[Signature]* January 1, 2014
ENGINEER OF DESIGN AND ENVIRONMENT

ISSUED 1-1-07

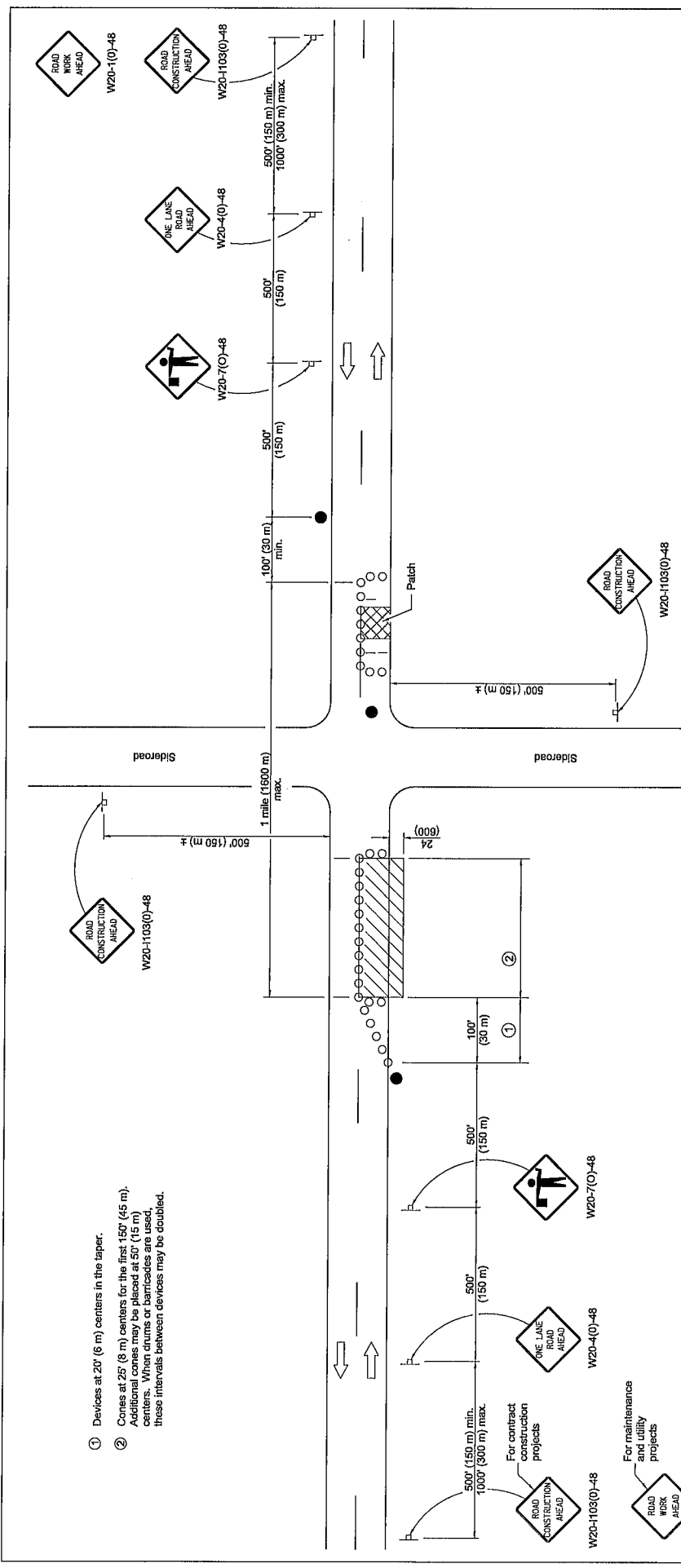

- ① Devices at 20' (6 m) centers in the taper.
- ② Cones at 25' (8 m) centers for the first 150' (45 m). Additional cones at 15' (5 m) centers. When drums or barricades are used, these intervals between devices may be doubled.

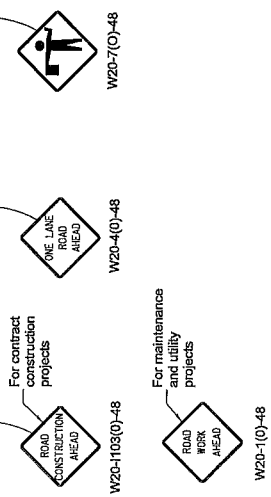

SYMBOLS

- Work area
- Sign
- Barricade or drum
- Cone, drum or barricade
- Flagger with traffic control sign

TYPICAL APPLICATIONS

- Isolated patching
- Utility operations
- Storm sewer
- Curbs
- Cable placement

GENERAL NOTES

This Standard is used where at any time, any vehicles, equipment, workers or their activities will encroach in the area between the center line and a line 24 (600) outside the edge of pavement for daylight operation.

When the distance between successive work areas exceeds 2000' (600 m), additional warning signs, flaggers, and taper shall be placed as shown.

All dimensions are in inches (millimeters) unless otherwise shown.

DATE	REVISIONS
1-1-19	Revised device spacing in taper.
1-1-11	Revised flagger sign.

**LANE CLOSURE, 2L 2W,
DAY ONLY,
FOR SPEEDS ≥ 45 MPH**

STANDARD 701201-05

Illinois Department of Transportation
 APPROVED January 1, 2019
 ENGINEER OF SAFETY PROJECTS AND ENGINEERING
 APPROVED January 1, 2019
 ENGINEER OF DESIGN AND ENVIRONMENT
 ISSUED 1-1-47

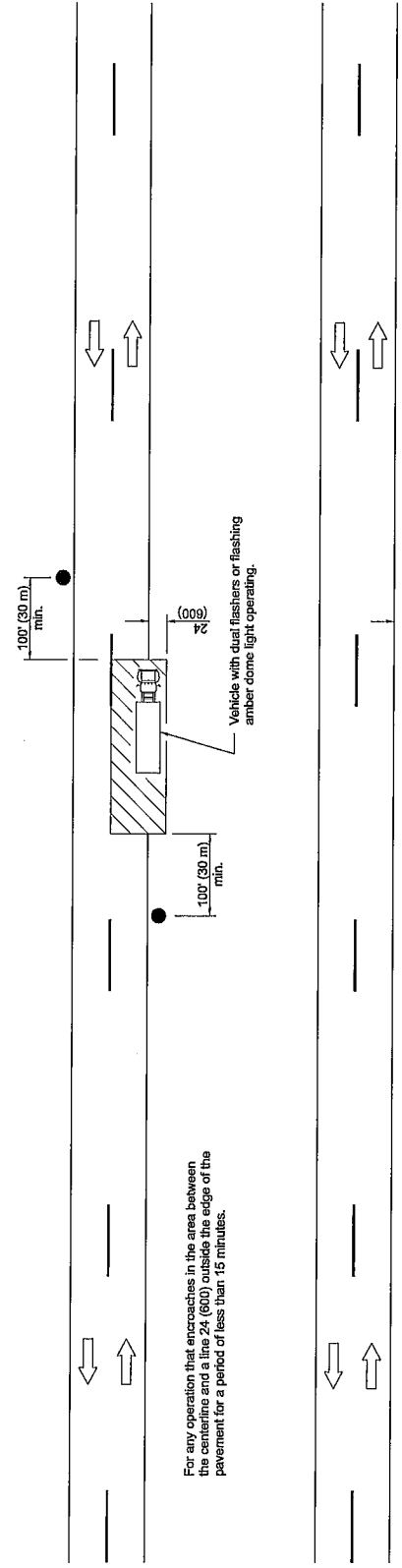

For any operation that encroaches in the area between the centerline and a line 24' (600) outside the edge of the pavement for a period of less than 15 minutes.

For any operation that is more than 24' (600) outside the edge of the pavement for a period of less than 60 minutes.

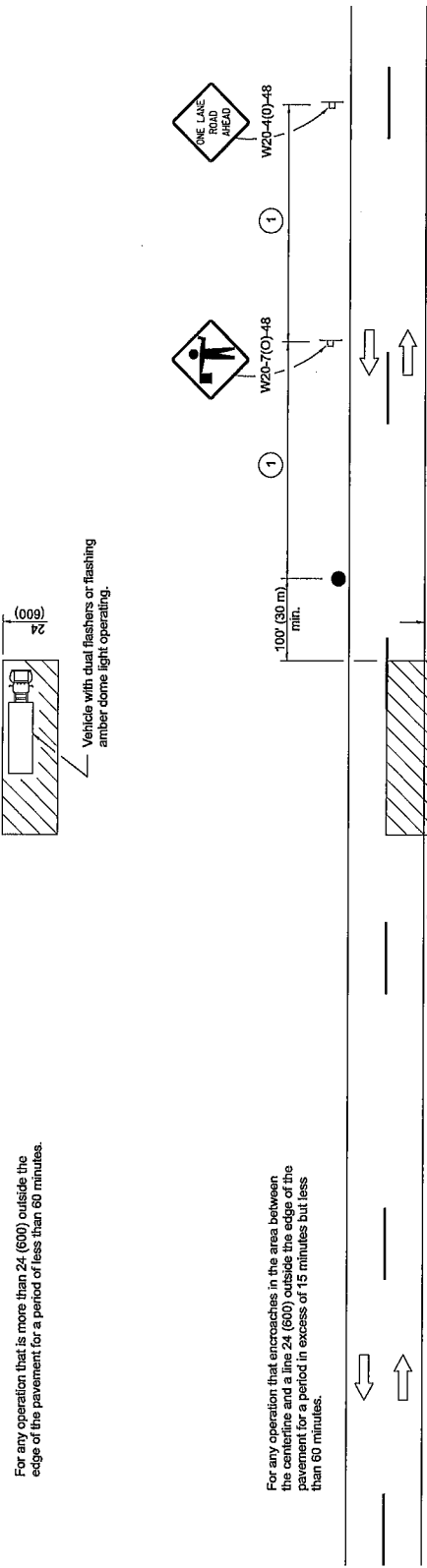

For any operation that encroaches in the area between the centerline and a line 24' (600) outside the edge of the pavement for a period in excess of 15 minutes but less than 60 minutes.

Posted Speed	Sign Spacing
55	500' (150 m)
50-45	350' (100 m)
<45	200' (60 m)

① = Refer to SIGN SPACING table for distances.

All dimensions are in inches (millimeters) unless otherwise shown.

LANE CLOSURE, 2L, 2W, SHORT TIME OPERATIONS

DATE	REVISIONS
1-1-11	Revised flagger sign.
1-1-09	Switched units to English (metric).

STANDARD 701301-04

TYPICAL APPLICATIONS

- Marking patches
- Field survey
- Striping
- Utility operations
- Cleaning up debris on pavement

SYMBOLS

- Work area
- Sign on portable or permanent support
- Flagger with traffic control sign

Illinois Department of Transportation

APPROVED: *[Signature]* January 1, 2011
 ENGINEER OF SAFETY ENGINEERING

APPROVED: *[Signature]* January 1, 2011
 ENGINEER OF DESIGN AND ENVIRONMENT

ISSUED 1-1-97

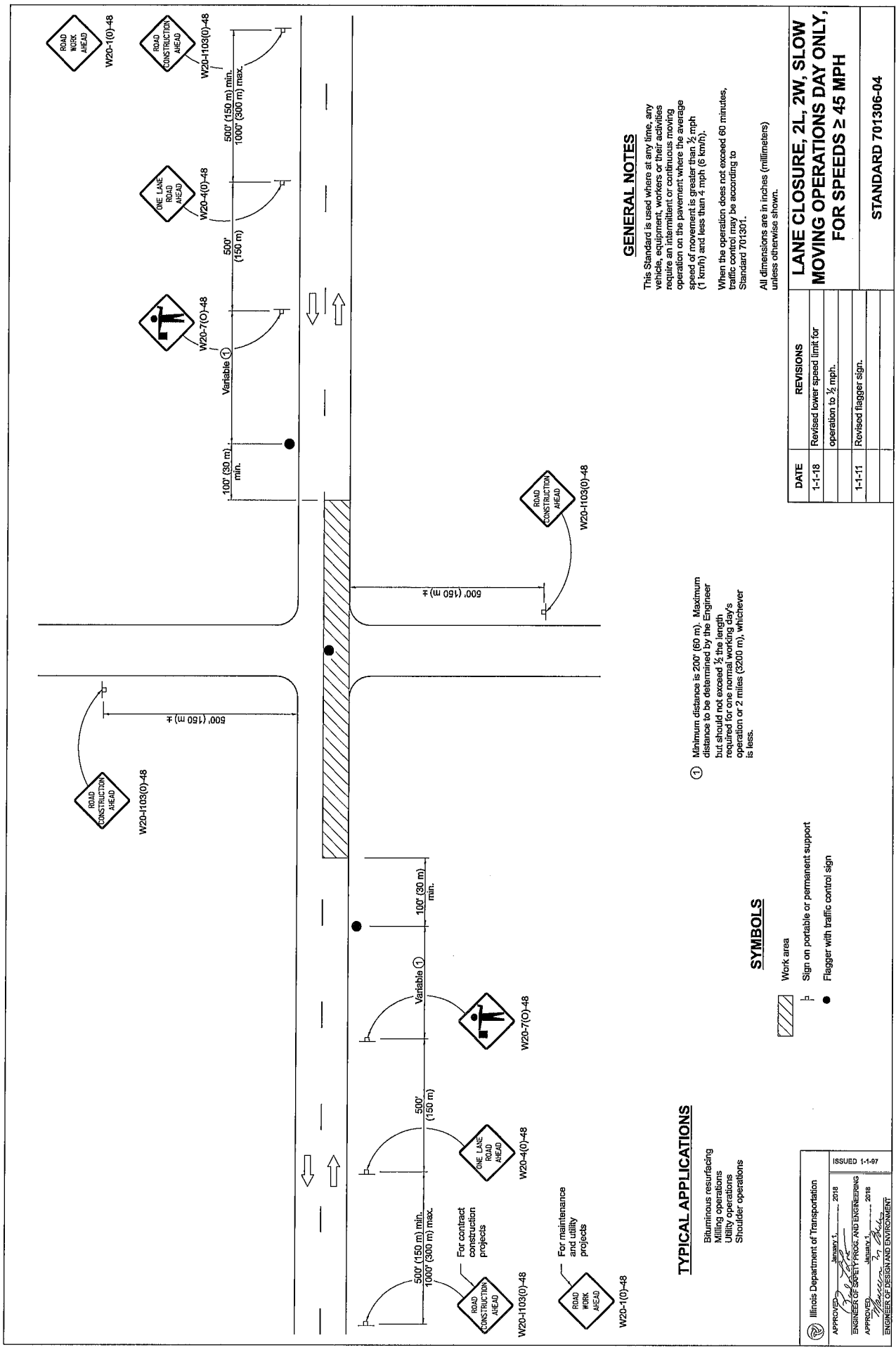

GENERAL NOTES

This Standard is used where at any time, any vehicle, equipment, workers or their activities require an intermittent or continuous moving operation on the pavement where the average speed of movement is greater than 1/2 mph (1 km/h) and less than 4 mph (6 km/h).
 When the operation does not exceed 60 minutes, traffic control may be according to Standard 701301.
 All dimensions are in inches (millimeters) unless otherwise shown.

① Minimum distance is 200' (60 m). Maximum distance to be determined by the Engineer but should not exceed 1/2 the length required for one normal working day's operation or 2 miles (3200 m), whichever is less.

TYPICAL APPLICATIONS

- Bluminous resurfacing
- Milling operations
- Utility operations
- Shoulder operations

SYMBOLS

- Work area
- Sign on portable or permanent support
- Flagger with traffic control sign

DATE	REVISIONS
1-1-18	Revised lower speed limit for operation to 1/2 mph.
1-1-11	Revised flagger sign.

LANE CLOSURE, 2L, 2W, SLOW MOVING OPERATIONS DAY ONLY, FOR SPEEDS ≥ 45 MPH

STANDARD 701306-04

Illinois Department of Transportation
 APPROVED: [Signature] January 1, 2018
 ENGINEER OF SAFETY/FROG AND ENGINEERING
 APPROVED: [Signature] January 1, 2018
 ENGINEER OF DESIGN AND ENVIRONMENT

ISSUED 1-1-97

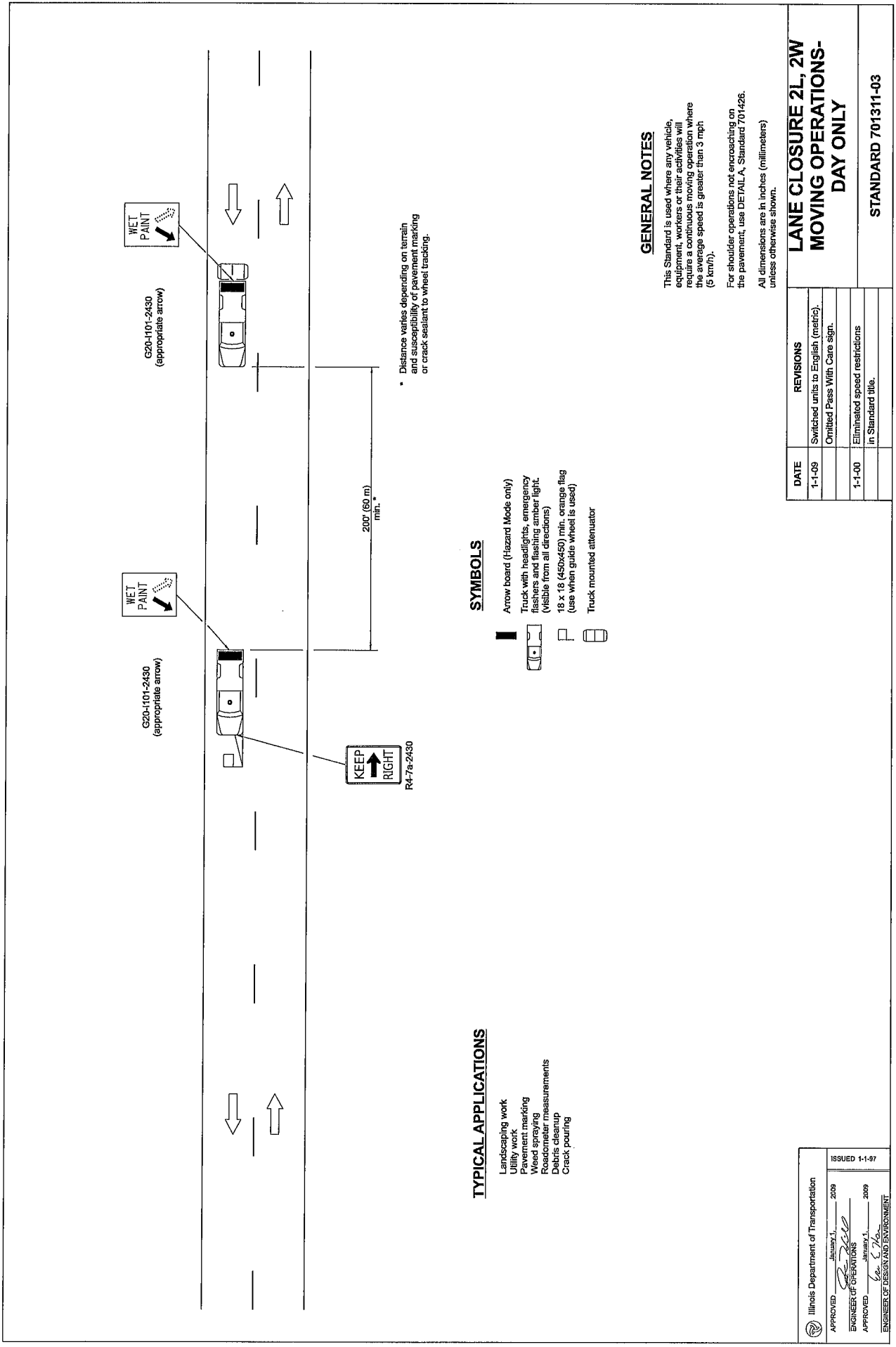

WET PAINT
↓

G20-101-2430
(appropriate arrow)

WET PAINT
↓

G20-101-2430
(appropriate arrow)

KEEP RIGHT
↑
R4-7a-2430

200' (60 m)
min.

* Distance varies depending on terrain and susceptibility of pavement marking or crack sealant to wheel tracking.

TYPICAL APPLICATIONS

- Landscaping work
- Utility work
- Pavement marking
- Weed spraying
- Roadometer measurements
- Debris cleanup
- Crack pouring

SYMBOLS

- Arrow board (Hazard Mode only)
- Truck with headlights, emergency flashers and flashing amber light. (Visible from all directions)
- 18 x 18 (450x450) mm, orange flag (use when guide wheel is used)
- Truck mounted attenuator

GENERAL NOTES

This Standard is used where any vehicle equipment, work zone or traffic control requires a continuous moving operation where the average speed is greater than 3 mph (5 km/h).

For shoulder operations not encroaching on the pavement, use DETAIL A, Standard 701428.

All dimensions are in inches (millimeters) unless otherwise shown.

DATE	REVISIONS
1-1-09	Switched units to English (metric). Omitted Pass With Care sign.
1-1-00	Eliminated speed restrictions in Standard title.

**LANE CLOSURE 2L, 2W
MOVING OPERATIONS-
DAY ONLY**

STANDARD 701311-03

Illinois Department of Transportation
ISSUED 1-1-97

APPROVED January 1, 2009
ENGINEER OF OPERATIONS
APPROVED January 1, 2009
ENGINEER OF DESIGN AND ENVIRONMENT

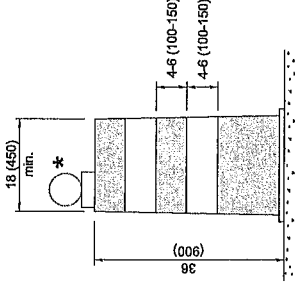
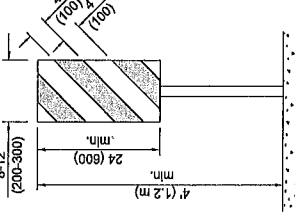
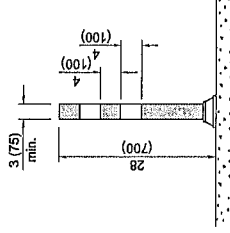
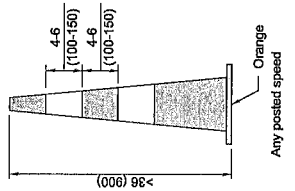
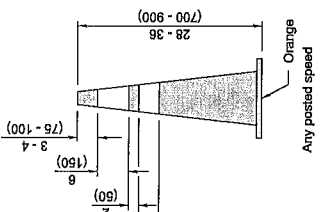
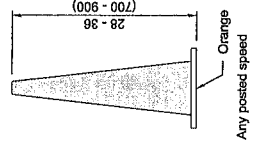
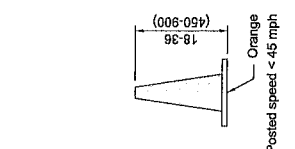

DAYTIME USE

CONES

DAY OR NIGHTTIME USE

TUBULAR MARKER

VERTICAL PANEL POST MOUNTED

DRUM

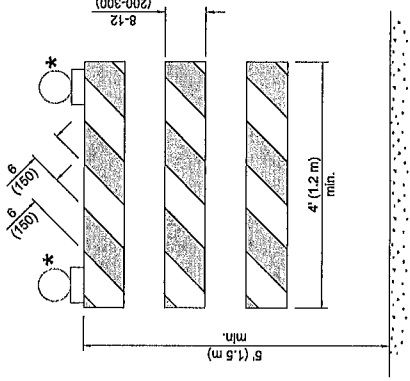
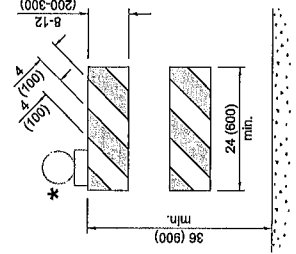
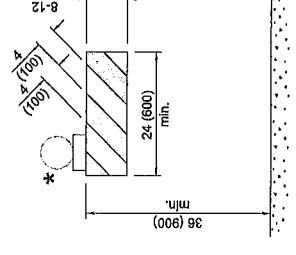

TYPE I BARRICADE

TYPE II BARRICADE

TYPE III BARRICADE

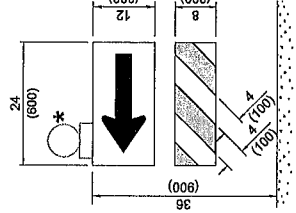

DIRECTION INDICATOR BARRICADE

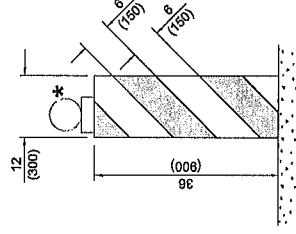

VERTICAL BARRICADE

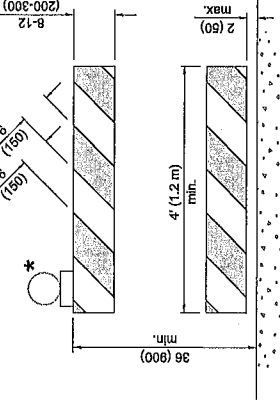

DETECTABLE PEDESTRIAN CHANNELIZING BARRICADE

* Warning lights (if required)

GENERAL NOTES

All heights shown shall be measured above the pavement surface.
All dimensions are in inches (millimeters) unless otherwise shown.

Illinois Department of Transportation
APPROVED: [Signature] 2024
ENGINEER OF SAFETY PROGRAM ENGINEERING
APPROVED: [Signature] 2024
ENGINEER OF DESIGN AND ENVIRONMENT

DATE	REVISIONS
1-1-24	Revised Type III Barricade notes (Sht. 3) & moved warning light on post mounted signs to top center.
1-1-19	Revised cones usage and added cones > 36" (900 mm) height.

TRAFFIC CONTROL DEVICES

STANDARD 701901-09

(Sheet 1 of 3)

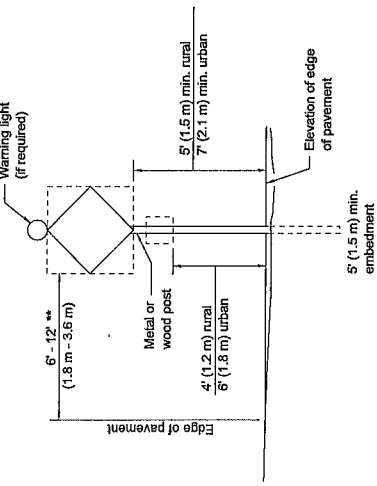

POST MOUNTED SIGNS

** When curb or paved shoulder are present this dimension shall be 24 (600) to the face of curb or 6' (1.8 m) to the outside edge of the paved shoulder.

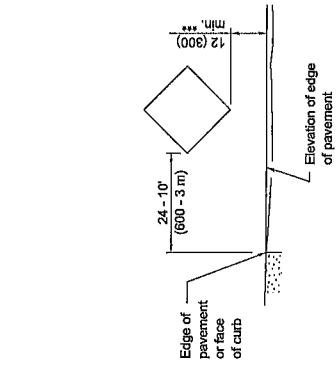

SIGNS ON TEMPORARY SUPPORTS

*** When work operations exceed four days, this dimension shall be 5' (1.5 m) min. If located behind other devices, the height shall be sufficient to be seen completely above the devices.

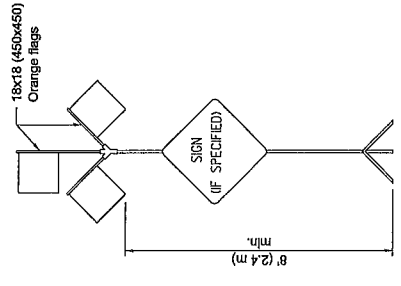

HIGH LEVEL WARNING DEVICE

ROAD CONSTRUCTION NEXT X MILES
G20-1104(0)-6036

END CONSTRUCTION
G20-1105(0)-6024

This signing is required for all projects 2 miles (3200 m) or more in length.

ROAD CONSTRUCTION NEXT X MILES sign shall be placed 500' (150 m) in advance of project limits.

END CONSTRUCTION sign shall be erected at the end of the job unless another job is within 2 miles (3200 m).

Dual sign displays shall be utilized on multi-lane highways.

WORK LIMIT SIGNING

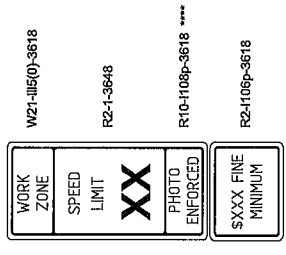

Sign assembly as shown on Standards or as allowed by District Operations.

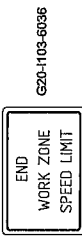

This sign shall be used when the above sign assembly is used.

HIGHWAY CONSTRUCTION SPEED ZONE SIGNS

**** R10-1108p shall only be used along roadways under the jurisdiction of the State.

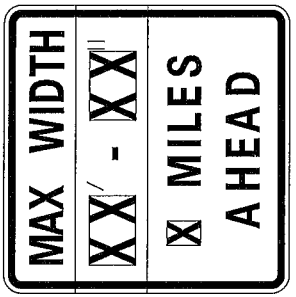
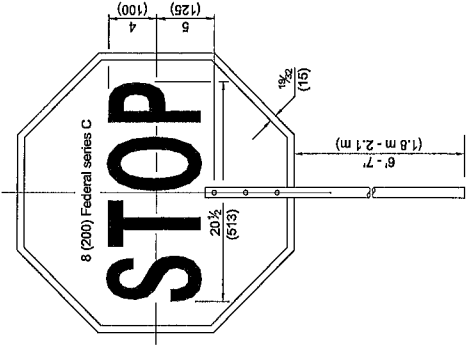

WIDTH RESTRICTION SIGN

XX-XX" width and X miles are variable.

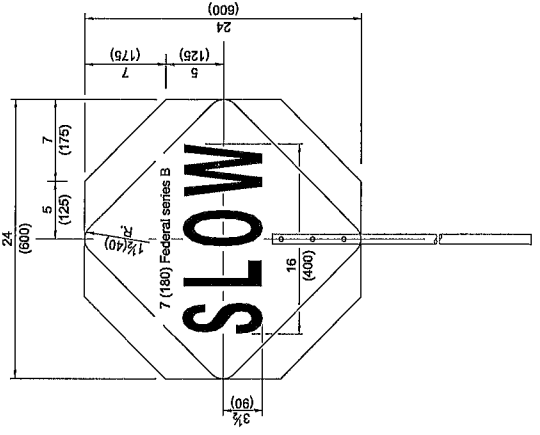

REVERSE SIDE

FRONT SIDE

FLAGGER TRAFFIC CONTROL SIGN

TRAFFIC CONTROL DEVICES

(Sheet 2 of 3)

STANDARD 701901-09

Illinois Department of Transportation

APPROVED: [Signature] 2024
 ENGINEER OF SAFETY PROGRAM ENGINEERING

APPROVED: [Signature] 2024
 ENGINEER OF DESIGN AND ENVIRONMENT

ISSUED 1-1-13

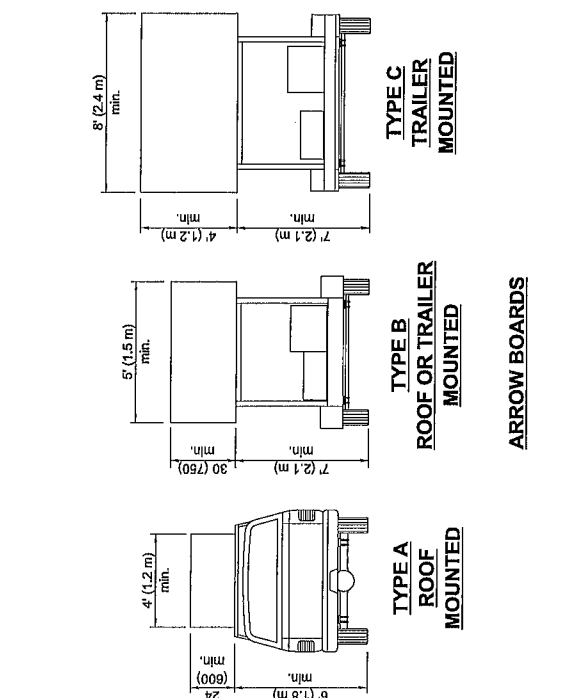
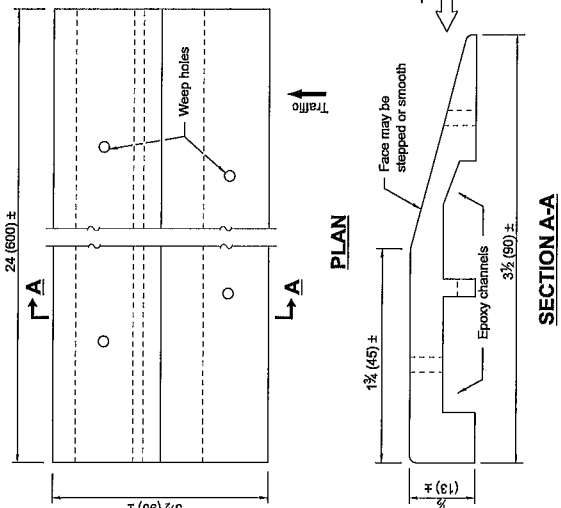
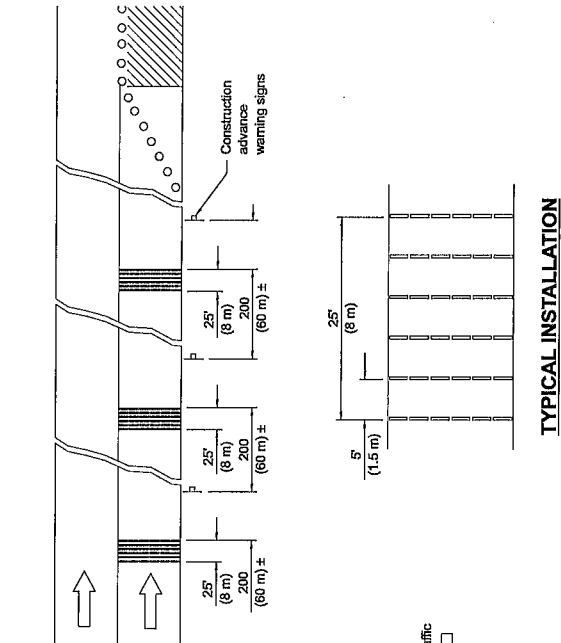

TEMPORARY RUMBLE STRIPS

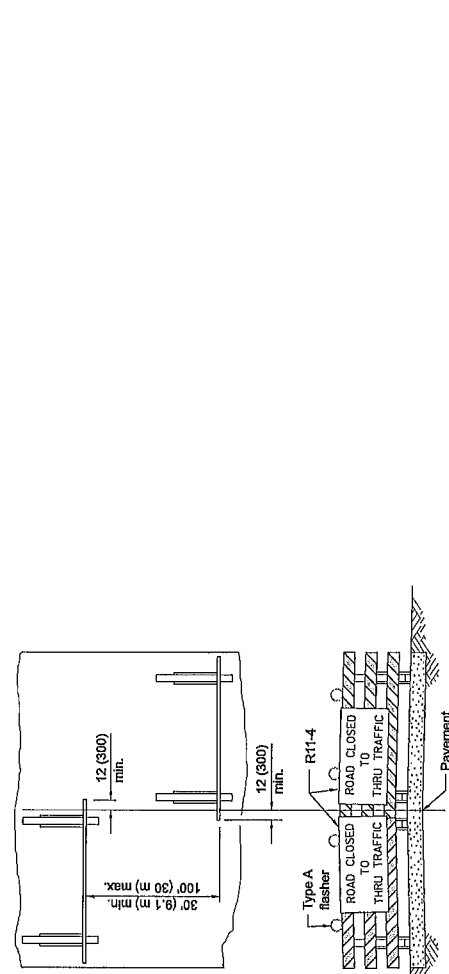

Illinois Department of Transportation
 APPROVED: *[Signature]* 2024
 ENGINEER OF SAFETY PROGRAMS AND ENGINEERING
 APPROVED: *[Signature]* 2024
 ENGINEER OF DESIGN AND ENVIRONMENT

ISSUED 1-1-13

TRAFFIC CONTROL DEVICES

STANDARD 701901-09

(Sheet 3 of 3)

INDEX OF SHEETS

- 1 COVER SHEET
- 2 SUMMARY OF QUANTITIES & GENERAL NOTES
- 3-5 TYPICAL SECTIONS
- 6-7 SCHEDULE OF QUANTITIES
- 8 CH 15 & CH 55 INTERSECTION DETAIL
- 9 CH 15, CH 30 & E 2350TH RD INTERSECTION DETAIL
- 10-11 DETAILS

STATE OF ILLINOIS
DEPARTMENT OF TRANSPORTATION
 PLANS FOR PROPOSED
MOTOR FUEL TAX IMPROVEMENTS
LASALLE COUNTY
COUNTY HIGHWAY 15
SECTION 23-00409-00-RS
HMA RESURFACING

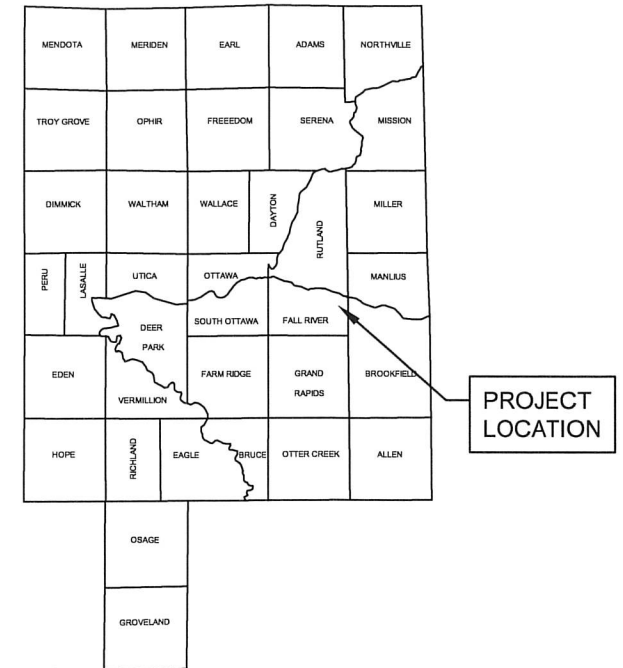

PREVIOUS SECTIONS

- 75-00214-01-RP
- 84-00228-00-RS
- 90-00247-00-WR
- 00-00289-00-SM

ATTENTION CONTRACTORS

THE ILLINOIS DEPARTMENT OF TRANSPORTATION BUREAU OF MATERIALS AND PHYSICAL RESEARCH "PROJECT PROCEDURES GUIDE" IS APPLICABLE TO THIS PROJECT.

FUNCTIONAL CLASS: MAJOR COLLECTOR (RURAL)
 2024 ADT: 3000
 DESIGN SPEED: 50 MPH
 3R GUIDELINES

IMPROVEMENT BEGINS
STATION 9+50

IMPROVEMENT ENDS
STATION 57+22

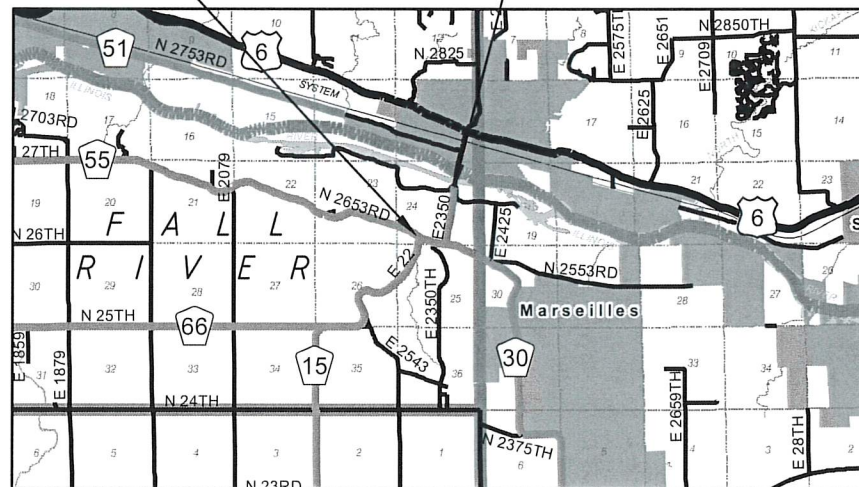

STA 10+00 = WEST EDGE OF SN 050-3047

STA 57+22 = SOUTH ROADWAY APPROACH (START CONCRETE PAVEMENT) TO THE MARSEILLES ILLINOIS RIVER BRIDGE

CALL JULIE
 48 Hours Before You Dig.
 811 OR 1-800-892-0123

GROSS LENGTH = 4,772 FT = 0.904 MI
 NET LENGTH = 4,772 FT = 0.904 MI



THESE PLANS WERE PREPARED BY ME OR BY A FULL-TIME MEMBER OF MY STAFF WORKING UNDER MY PERSONAL SUPERVISION

Donald R. Ernat
 DONALD R. ERNAT, P.E.
 COUNTY ENGINEER
 I.R.P.E. #62-48810 11-30-25 EXP.

5/3/2024
 DATE

SUMMARY OF QUANTITIES

CODE NO.	PAY ITEM	UNIT	TOTAL QUANTITIES
20200500	EARTH EXCAVATION (WIDENING)	CU YD	3
40600275	BITUMINOUS MATERIALS (PRIME COAT)	POUND	119
40600290	BITUMINOUS MATERIALS (TACK COAT)	POUND	5,965
40600370	LONGITUDINAL JOINT SEALANT	FOOT	4,772
* 40600982	HOT-MIX ASPHALT SURFACE REMOVAL - BUTT JOINT	SQ YD	53
40604050	HOT-MIX ASPHALT SURFACE COURSE, IL-9.5, MIX "C", N50	TON	1,116
* 44000152	HOT-MIX ASPHALT SURFACE REMOVAL, ¾"	SQ YD	11,440
* 44000155	HOT-MIX ASPHALT SURFACE REMOVAL, 1 ¼"	SQ YD	2,457
48101200	AGGREGATE SHOULDERS, TYPE B	TON	204
* 70300100	SHORT TERM PAVEMENT MARKING	FOOT	2,322
78001110	PAINT PAVEMENT MARKING - LINE 4"	FOOT	5,626
78001130	PAINT PAVEMENT MARKING - LINE 6"	FOOT	8,977
78004280	PREFORMED PLASTIC PAVEMENT MARKING, TYPE B - INLAID - LINE 24"	FOOT	49
* X4401198	HOT-MIX ASPHALT SURFACE REMOVAL, VARIABLE DEPTH	SQ YD	194

* SEE SPECIAL PROVISIONS

HIGHWAY STANDARDS

701006-05	OFF-RD OPERATIONS, 2L, 2W, 15' TO 24" FROM PAVEMENT EDGE
701011-04	OFF-RD MOVING OPERATIONS, 2L, 2W, DAY ONLY
701201-05	LANE CLOSURE, 2L, 2W, DAY ONLY, FOR SPEEDS ≥ 45 MPH
701301-04	LANE CLOSURE, 2L, 2W, SHORT TIME OPERATIONS
701306-04	LANE CLOSURE, 2L, 2W, SLOW MOVING OPERATIONS DAY ONLY, FOR SPEEDS ≥ 45 MPH
701311-03	LANE CLOSURE, 2L, 2W, MOVING OPERATIONS - DAY ONLY
701901-09	TRAFFIC CONTROL DEVICES

GENERAL NOTES

THE THICKNESS OF HMA MIXTURES SHOWN ON THE PLANS IS THE NOMINAL THICKNESS. DEVIATIONS FROM THE NOMINAL THICKNESS WILL BE PERMITTED WHEN SUCH DEVIATIONS OCCUR DUE TO IRREGULARITIES IN THE EXISTING SURFACE OR BASE ON WHICH THE HMA MIXTURE IS PLACED.

THE HMA SURFACE OF ALL MAILBOX TURNOUTS, PRIVATE ENTRANCES, COMMERCIAL ENTRANCES AND SIDE ROADS SHALL BE MADE NEATLY, IN A WORKMANLIKE MANNER, AND SHALL ACCURATELY CONFORM TO THE SHAPES AND DIMENSIONS SHOWN ON THE PLAN DETAILS. IF REQUIRED BY THE ENGINEER, THE CONTRACTOR SHALL SAW CUT THE HMA SURFACE TO CONFORM TO THE SHAPES AND DIMENSIONS SHOWN ON THE PLAN DETAILS. THIS WORK WILL BE INCLUDED IN THE COST OF THE HMA SURFACE.

THE ENGINEER WILL BE THE SOLE JUDGE CONCERNING CURING TIME FOR THE VARIOUS HMA LIFTS.

ON EXISTING PAVEMENT WHICH MAY BE SUPERELEVATED, THE NEW HMA PAVEMENT SHALL BE BUILT WITH THE SAME SUPERELEVATION UNLESS NEW SUPERELEVATION RATES ARE GIVEN ON THE PLANS.

COMMITMENTS

NONE

THE FOLLOWING RATES OF APPLICATION HAVE BEEN USED IN CALCULATING PLAN QUANTITIES:

PRIME COAT	0.25 LB / SQ FT
TACK COAT	0.05 LB / SQ FT (ON EX HMA)
	0.025 LB / SQ FT (ON NEW HMA)
HOT-MIX ASPHALT	112 LB / SQ FT / IN
GRANULAR MATERIALS	2.05 TON / CU YD
SHORT TERM PAVEMENT MARKING	10 FT / 40 FT

HMA MIXTURE REQUIREMENTS

LOCATION(S):	ENTIRE PROJECT
MIXTURE USE(S):	SURFACE
PG:	PG64-22
DESIGN AIR VOIDS:	4% @ N50
MIXTURE COMPOSITION:	IL-9.5
FRICTION AGGREGATE:	MIX "C"
MIXTURE WEIGHT:	112 LB / SQ YD / IN
QUALITY MANAGEMENT PROGRAM:	QC/QA
SUBLOT SIZE:	N/A
MATERIAL TRANSFER DEVICE:	NO
DENSITY TEST METHOD:	LR1030

SECTION

23-00409-00-RS

SUMMARY OF QUANTITIES

LASALLE COUNTY
HIGHWAY DEPARTMENT
1400 N. 27TH ROAD - P.O. BOX 128 - OTTAWA, ILLINOIS 61350
PHONE (815) 434-0743 FAX (815) 434-0747



HWY. NO.

CH 15

SHEET NO.

2 of 11

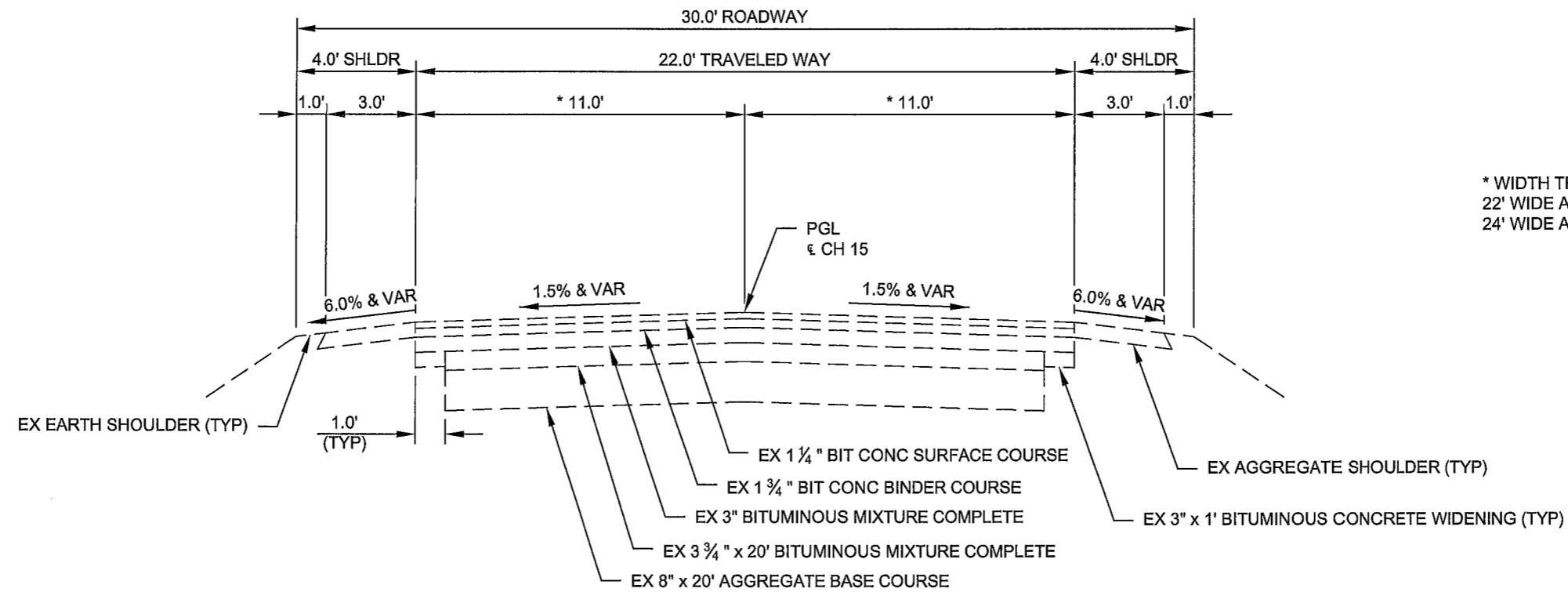

* WIDTH TRANSITIONS FROM
22' WIDE AT STA 23+99.50 TO
24' WIDE AT STA 24+89.50.

EXISTING TYPICAL SECTION

STA 9+50 TO STA 27+08

SUPERELEVATION TYPICALS NOT SHOWN,
EXISTING PAVEMENT STRUCTURE DOES NOT CHANGE.

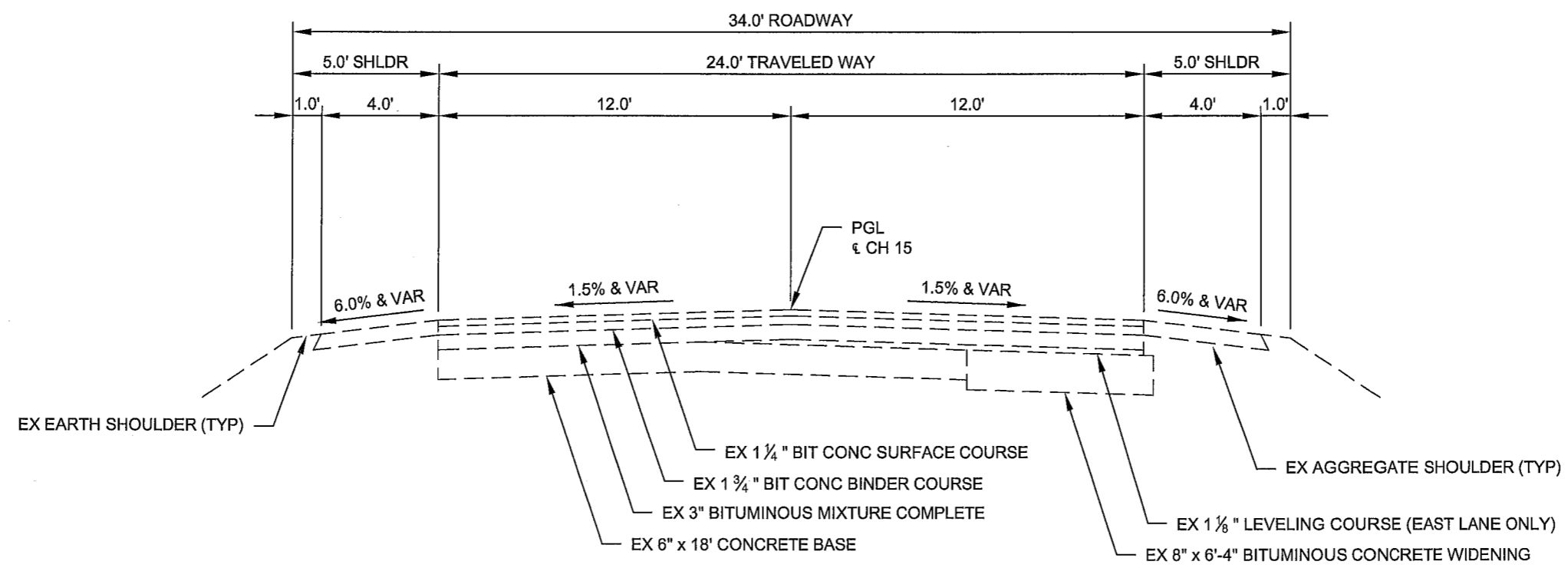

EXISTING TYPICAL SECTION

STA 27+08 TO STA 57+22

SECTION

23-00409-00-RS

TYPICAL SECTIONS

LASALLE COUNTY
HIGHWAY DEPARTMENT
1400 N. 27TH ROAD - P. O. BOX 128 - OTTAWA, ILLINOIS 61350
PHONE (815) 434-0743 FAX (815) 434-0747



HWY. NO.

CH 15

SHEET NO.

3 of 11

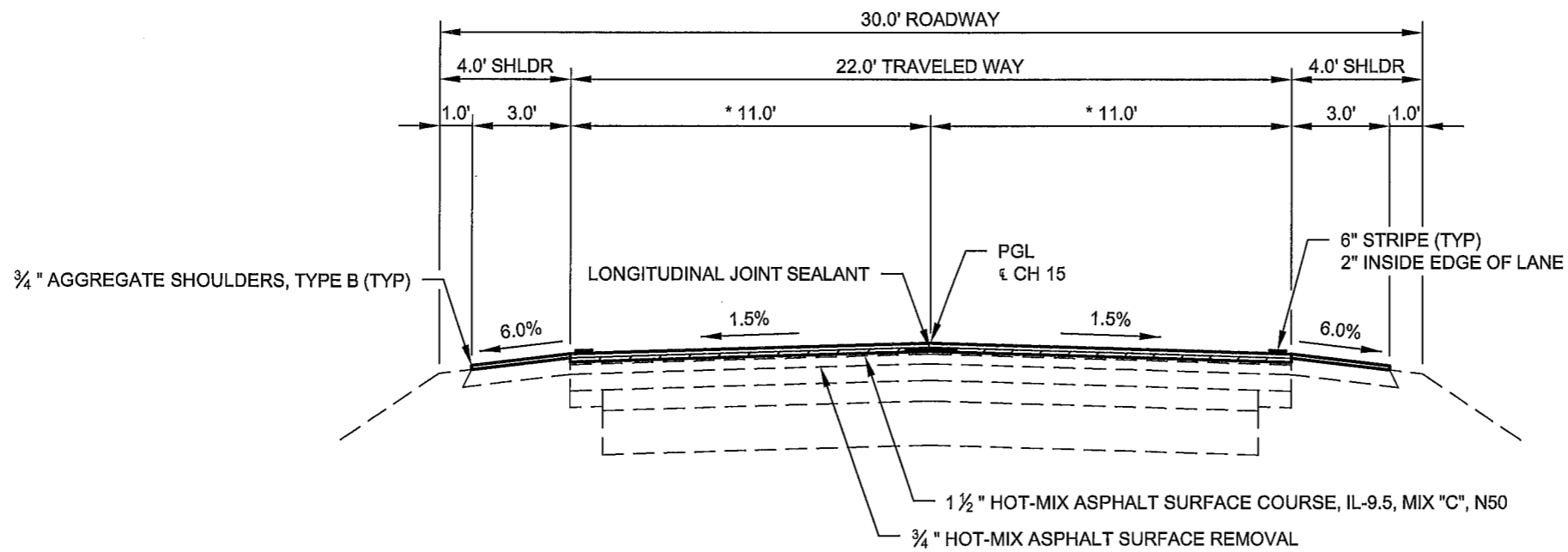

PROPOSED TYPICAL SECTION

STA 9+50 TO STA 10+30
 STA 12+49.50 TO STA 18+99.50
 STA 25+15.64 TO STA 27+08

SN 050-3047 = STA 10+00 TO 10+30

* WIDTH TRANSITIONS FROM
 22' WIDE AT STA 23+99.50+00 TO
 24' WIDE AT STA 24+89.50.

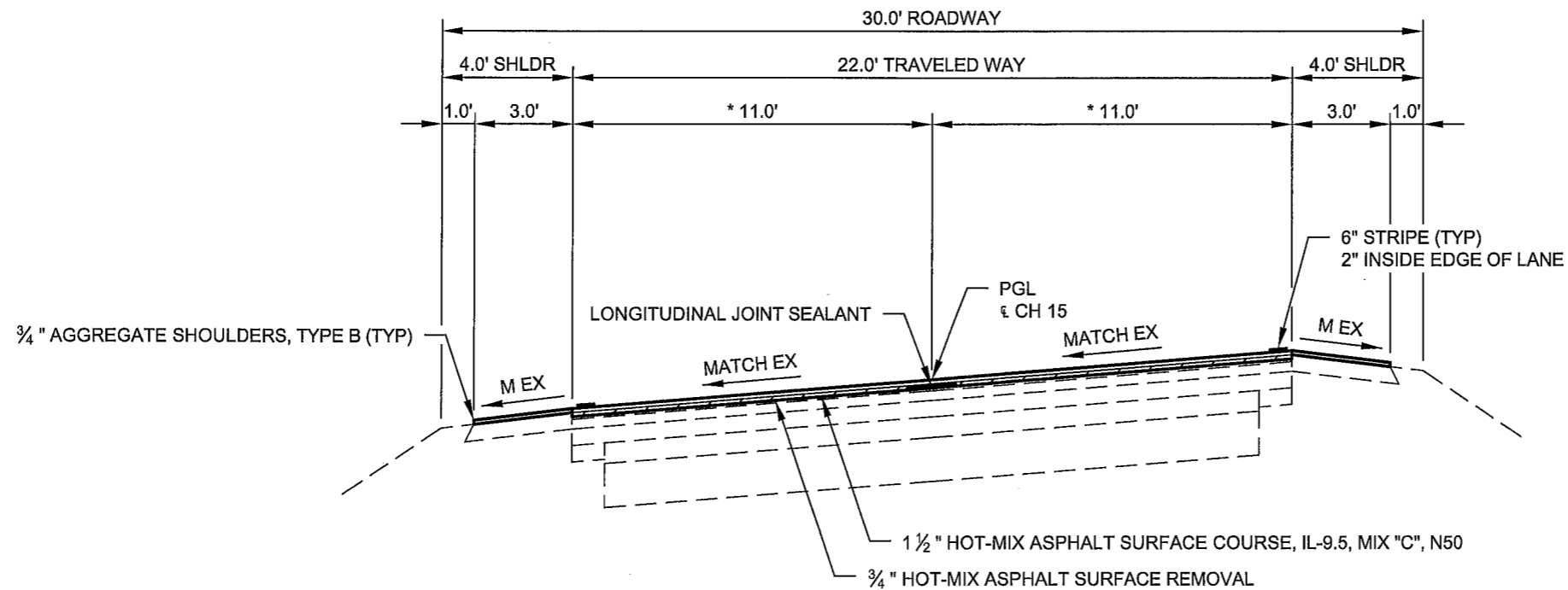

PROPOSED TYPICAL SECTION

STA 10+30 TO STA 12+49.50
 STA 18+99.50 TO STA 25+15.64

SECTION

23-00409-00-RS

TYPICAL SECTIONS

LASALLE COUNTY
 HIGHWAY DEPARTMENT
 1400 N. 27TH ROAD - P. O. BOX 128 - OTTAWA, ILLINOIS 61350
 PHONE (815) 434-0743 FAX (815) 434-0747



HWY. NO.

CH 15

SHEET NO.

4 of 11

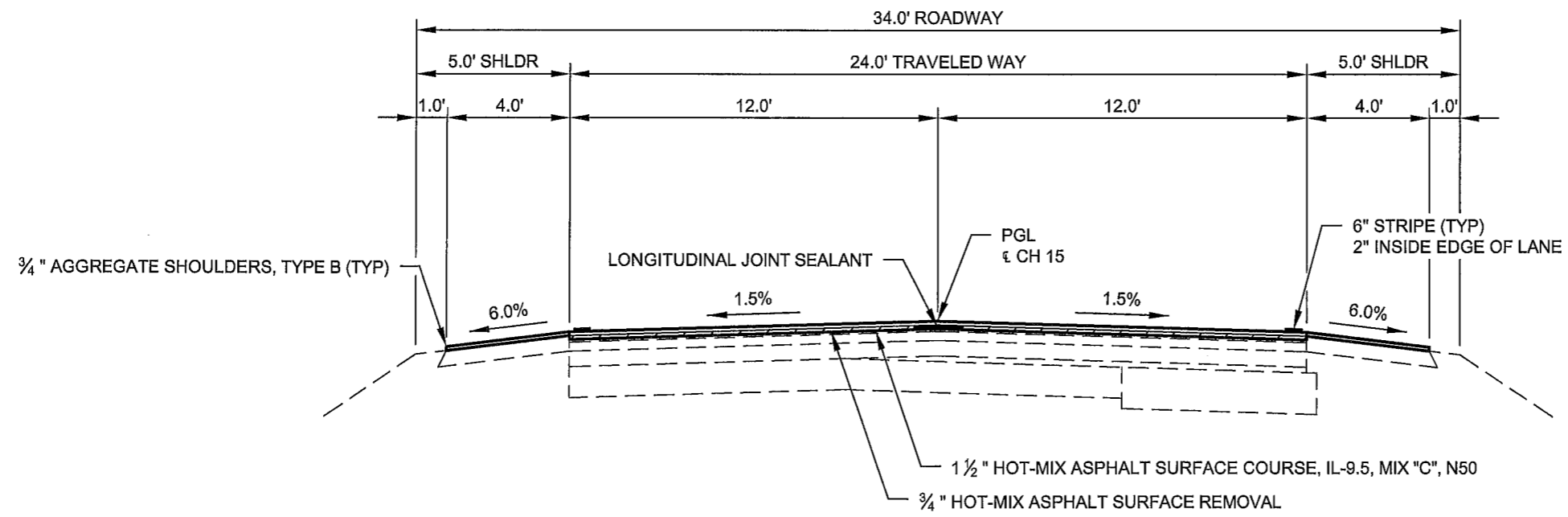

PROPOSED TYPICAL SECTION
STA 27+08 TO STA 57+22

SECTION

23-00409-00-RS

TYPICAL SECTIONS

LASALLE COUNTY
HIGHWAY DEPARTMENT
1400 N. 27TH ROAD - P. O. BOX 128 - OTTAWA, ILLINOIS 61350
PHONE (815) 464-0743 FAX (815) 464-0747



HWY. NO.

CH 15

SHEET NO.

5 of 11

PAVEMENT SCHEDULE										
STATION TO STATION	SURFACE WIDTH	AGGREGATE SHOULDER WIDTH	LENGTH	AREA	* HOT-MIX ASPHALT SURFACE REMOVAL	BITUMINOUS MATERIALS (PRIME COAT)	BITUMINOUS MATERIALS (TACK COAT)	LONGITUDINAL JOINT SEALANT	HOT-MIX ASPHALT SURFACE COURSE, IL-9.5, MIX "C", N50	AGGREGATE SHOULDERS, TYPE B
					¾ "					
	FOOT	FOOT	FOOT	SQ YD	SQ YD	POUND	POUND	FOOT	TON	TON
9+50 TO 23+99.50	22	3	1,450	3,543.2	3,445.4	0.0	1,594.4	1,449.5	297.6	41.3
23+99.50 TO 24+89.50	23	3	90	230.0	176.7	0.0	103.5	90.0	19.3	2.6
24+89.50 TO 27+08	24	3	219	582.7	0.0	0.0	262.2	218.5	48.9	6.2
27+08 TO 57+22	24	4	3,014	8,037.3	7,654.6	0.0	3,616.8	3,014.0	675.1	114.4
PAVED SHOULDERS =				129.1	129.1	0.0	58.1	0.0	9.0	0.0
INTERSECTIONS, ENTRANCES & MAILBOX TURNOUTS =				733.3	34.3	119.3	330.1	0.0	66.1	39.0
TOTALS =				13,255.6	11,440.1	119.3	5,965.1	4,772.0	1,116.0	203.5

* HOT-MIX ASPHALT SURFACE REMOVAL, ¾ " HAS BEEN ADJUSTED IN THIS TABLE TO REFLECT THE INTERSECTION DETAIL SHEETS. SEE SHEETS 8 AND 9 OF 11.

INTERSECTIONS, ENTRANCES, & MAILBOX TURNOUTS											
STATION	SIDE	TYPE	EX SURF	THROAT WIDTH	O/S FROM EOP	AREA	BIT MATL PRIME CT	BIT MATL TACK CT	¾ " HMA REM	HMA SURFACE	* AGG SHLDRS
				FOOT	FOOT	SQ YD	POUND	POUND	SQ YD	TON	TON
9+65	RT	FE	HMA APP	16	3	6.3	0.0	2.8	6.3	0.5	5
10+97	LT	PE	HMA	13	10	19.2	0.0	8.6	0.0	1.6	1
11+17	RT	CH 15 SOUTH	HMA	SEE DETAIL SHEET		111.3	0.0	50.1	0.0	9.3	1
11+64	LT	MBTO	HMA	-	2	10.7	0.0	4.8	10.7	0.9	0
11+79	LT	PE	HMA	10	10	15.9	0.0	7.2	0.0	1.3	1
12+80	LT	FE	AGG	16	3	6.3	14.2	2.8	0.0	1.1	5
27+08	CL	**	HMA	SEE DETAIL SHEET		340.6	0.0	153.3	0.0	28.6	1
31+02	LT	FE	AGG	48	3	17.0	38.3	7.7	0.0	2.9	5
33+28	RT	FE	AGG	32	3	11.7	26.3	5.3	0.0	2.0	5
40+59	RT	FE	AGG	32	3	11.7	26.3	5.3	0.0	2.0	5
51+37	LT	MBTO	HMA	-	3	17.3	0.0	7.8	17.3	1.5	0
51+47	LT	PE	HMA	14	10	20.4	0.0	9.2	0.0	1.7	1
52+33	LT	FE	AGG	16	3	6.3	14.2	2.8	0.0	1.1	5
53+60	LT	PE	HMA	15	6	14.8	0.0	6.7	0.0	1.2	1
54+46	LT	MBTO	HMA	W/IN PAVED SHLDR		0.0	0.0	0.0	0.0	0.0	0
54+53	LT	PE	HMA	13	6	13.5	0.0	6.1	0.0	1.1	1
55+31	LT	MBTO	HMA	W/IN PAVED SHLDR		0.0	0.0	0.0	0.0	0.0	0
55+36	LT	PE	HMA	17	3	10.5	0.0	4.7	0.0	0.9	1
56+19	LT	MBTO	HMA	W/IN PAVED SHLDR		0.0	0.0	0.0	0.0	0.0	0
56+31	LT	PE	CONC	SKIP		0.0	0.0	0.0	0.0	0.0	0
56+50	RT	ILLINI PARK	HMA	63	10	99.8	0.0	44.9	0.0	8.4	1
TOTALS =						733.3	119.3	330.1	34.3	66.1	39

* AGGREGATE SHOULDERS, TYPE B ARE ESTIMATED AT 5 TONS PER FIELD ENTRANCE AND 1 TON PER PRIVATE ENTRANCE, COMMERCIAL ENTRANCE AND INTERSECTION.

** CH 15, CH 30 & E 2350TH RD

PAVED SHOULDERS			
STATION TO STATION	SIDE	WIDTH	AREA
		FOOT	SQ YD
* 10+00 TO 10+30	LT	4	13.3
* 10+00 TO 10+30	RT	4	13.3
53+60 TO 55+65	LT	4.5	102.5
TOTAL =			129.1

* SN 050-3047

SECTION

23-00409-00-RS

SCHEDULE OF QUANTITIES

LASALLE COUNTY
HIGHWAY DEPARTMENT
1400 N. 27TH ROAD - P.O. BOX 128 - OTTAWA, ILLINOIS 61360
PHONE (815) 434-0743 FAX (815) 434-0747



HWY. NO.

CH 15

SHEET NO.

6 of 11

PAINT PAVEMENT MARKING SCHEDULE					
STATION TO STATION	LOCATION	DESCRIPTION	PAINT PAVEMENT MARKING		PREFORMED PLASTIC PAVEMENT MARKING, TYPE B - INLAID
			LINE 4"	LINE 6"	LINE 24"
			FOOT	FOOT	FOOT
9+50 TO 26+21	EDGE LINE LT	WHITE, OMIT SIDE ROADS		1,671	
9+50 TO 26+21	EDGE LINE RT	WHITE, OMIT SIDE ROADS		1,536	
28+33 TO 57+22	EDGE LINE LT	WHITE, OMIT SIDE ROADS		2,939	
28+33 TO 57+22	EDGE LINE RT	WHITE, OMIT SIDE ROADS		2,831	
@ EX STOP SIGN	CH 15 EAST INT	WHITE - STOP BAR			12
@ EX STOP SIGN	CH 15 SOUTH INT	WHITE - STOP BAR			17
@ EX STOP SIGN	CH 30 INT	WHITE - STOP BAR			20
9+50 TO 26+76	CENTERLINE	YELLOW - DOUBLE YELLOW	3,452		
27+69 TO 46+55	CENTERLINE	YELLOW - SKIP DASH	707		
46+55 TO 57+22	CENTERLINE	YELLOW - SKIP LT / SOLID RT	1,467		
TOTALS =			5,626	8,977	49

HOT-MIX ASPHALT SURFACE REMOVAL, 1 1/4"		
STATION TO STATION	TYPE	AREA SQ YD
9+50 TO 13+18.80	BEGIN / CH 15 SOUTH INT	1,012.8
24+69.50 TO 28+63.50	CH 15 / CH 30 / E 2350TH RD INT	1,444.3
TOTAL =		2,457.1

SHORT TERM PAVEMENT MARKING		
STATION TO STATION	CENTERLINE	STOP BAR
	SKIP DASH - YELLOW - 4"	SOLID - WHITE - 4"
	3 APPLICATIONS	
FOOT		
9+50 TO 57+22	1,440	882
TOTAL =		2,322

HOT-MIX ASPHALT SURFACE REMOVAL, VARIABLE DEPTH			
STATION	SIDE	TYPE	AREA
			SQ YD
10+97	LT	PE	19.2
11+79	LT	PE	15.9
51+47	LT	PE	20.4
53+60	LT	PE	14.8
54+53	LT	PE	13.5
55+36	LT	PE	10.5
56+50	RT	ILLINI STATE PARK	99.8
TOTAL =			194.1

HOT-MIX ASPHALT SURFACE REMOVAL - BUTT JOINT			
STATION	SIDE	TYPE	AREA
			SQ YD
57+22	CL	CONST END	53.3
TOTAL =			53.3

EARTH EXCAVATION (WIDENING)			
STATION	SIDE	TYPE	VOLUME
			CU YD
12+80	LT	FE	0.4
31+02	LT	FE	1.1
33+28	RT	FE	0.7
40+59	RT	FE	0.7
52+33	LT	FE	0.4
TOTAL =			3.3

SECTION

23-00409-00-RS

SCHEDULE OF QUANTITIES

LASALLE COUNTY
HIGHWAY DEPARTMENT
1400 N. 27TH ROAD - P.O. BOX 128 - OTTAWA, ILLINOIS 61350
PHONE (815) 434-0743 FAX (815) 434-0747



HWY. NO.

CH 15

SHEET NO.

7 of 11

PAVEMENT QUANTITIES OF RADIUS AREAS OUTSIDE OF 22' WIDE PAVEMENT AND THE CH 15 SOUTH INTERSECTION ARE ACCOUNTED FOR IN THE "INTERSECTIONS, ENTRANCES, & MAILBOX TURNOUTS" TABLE AS STA 11+17. SEE SHEET 6 OF 11.



SCALE: 1" = 30'

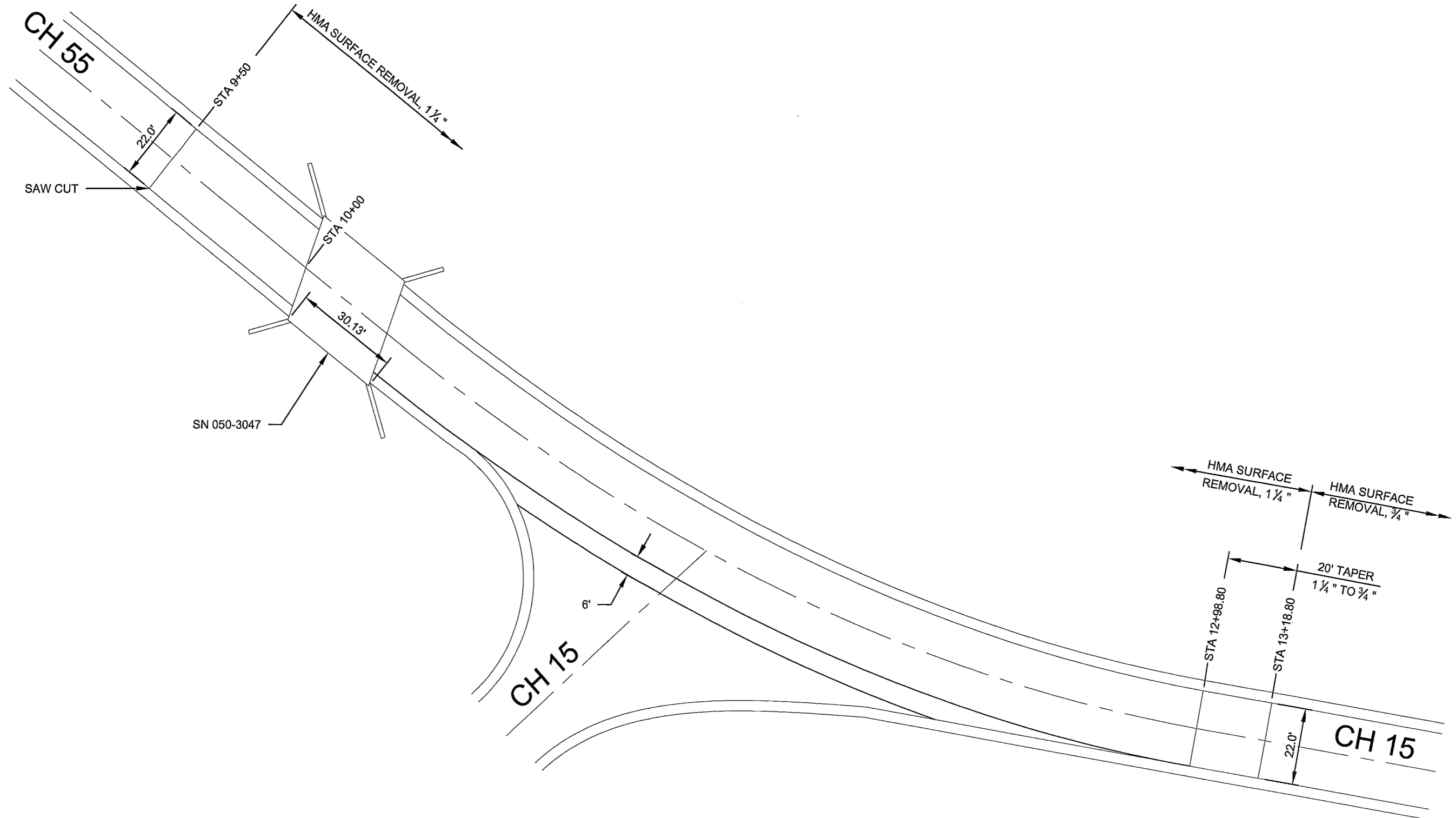

SECTION

23-00409-00-RS

CH 15 & CH 55
INTERSECTION DETAIL

LASALLE COUNTY
HIGHWAY DEPARTMENT
1400 N. 27TH ROAD - P.O. BOX 128 - OTTAWA, ILLINOIS 61350
PHONE (815) 434-0743 FAX (815) 434-0747



HWY. NO.

CH 15

SHEET NO.

8 of 11

PAVEMENT QUANTITIES OF RADIUS AREAS OUTSIDE OF 24' WIDE PAVEMENT AND THE CH 30 INTERSECTION ARE ACCOUNTED FOR IN THE "INTERSECTIONS, ENTRANCES, & MAILBOX TURNOUTS" TABLE AS STA 27+08. SEE SHEET 6 OF 11.

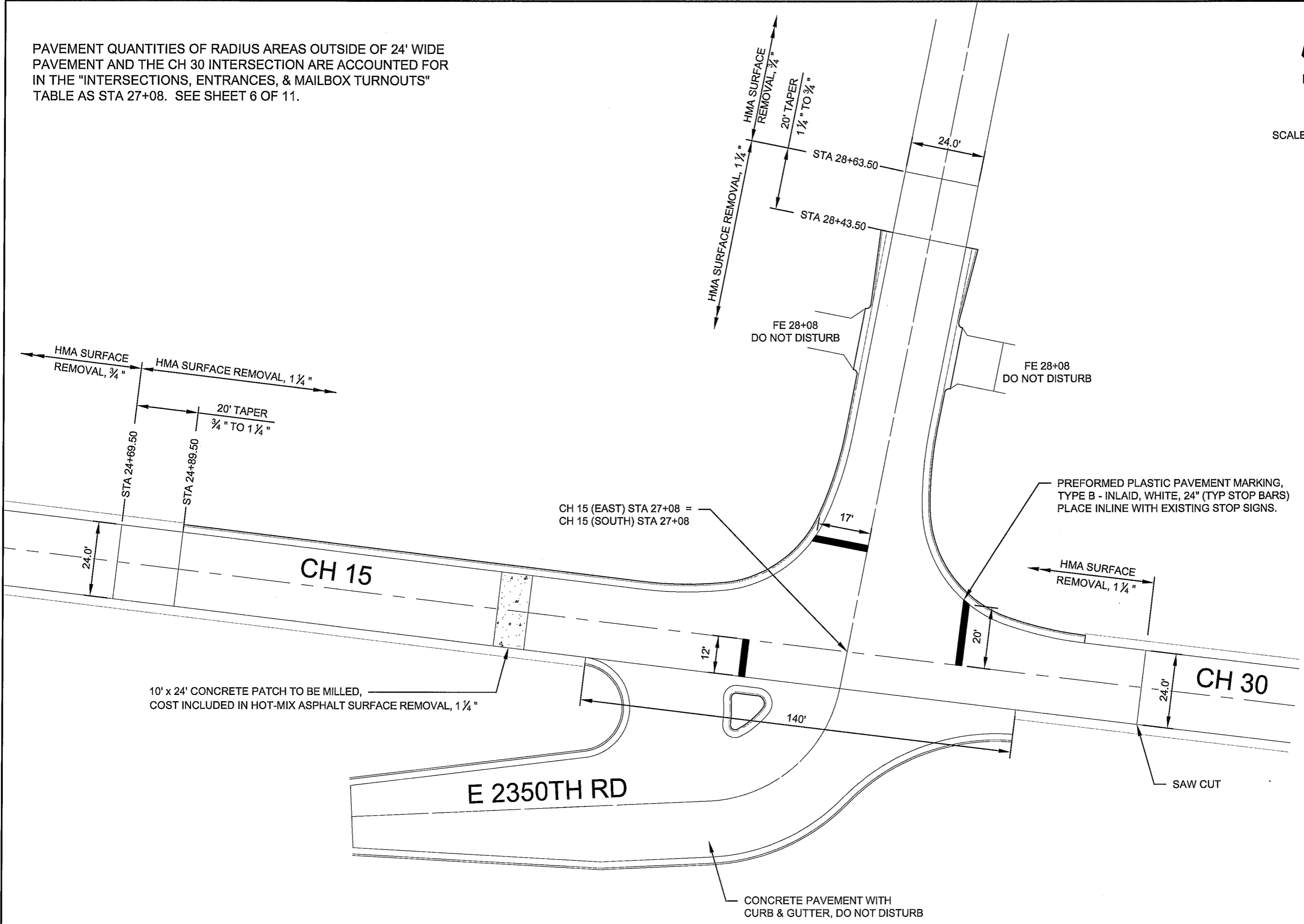

SECTION
23-00409-00-RS

CH 15, CH 30 & E 2350TH RD
INTERSECTION DETAIL

LASALLE COUNTY
HIGHWAY DEPARTMENT
1400 N. 27TH ROAD - P.O. BOX 128 - OTTAWA, ILLINOIS 61360
PHONE (815) 434-0743 FAX (815) 434-0747

HWY. NO.
CH 15

SHEET NO.
9 of 11

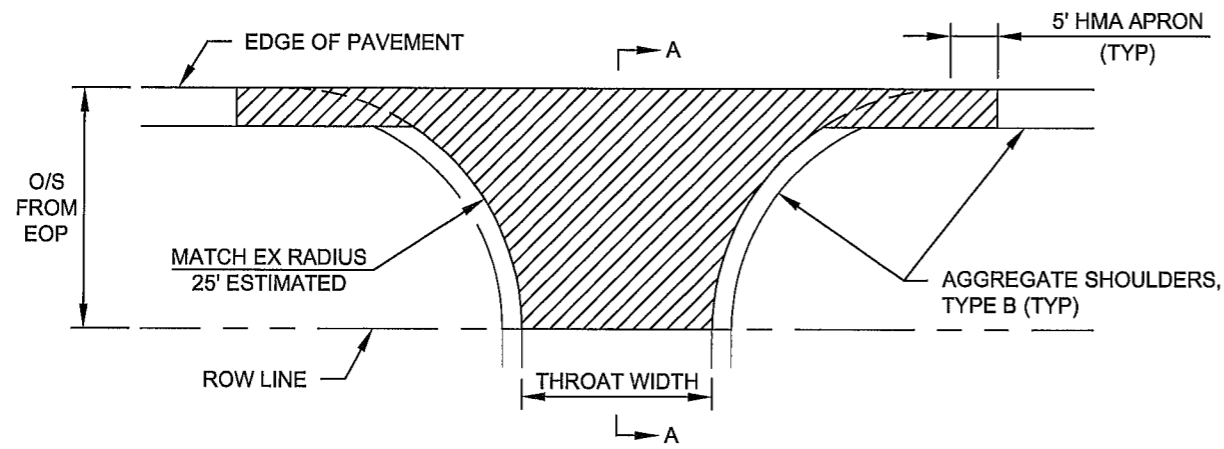

TYPICAL INTERSECTION

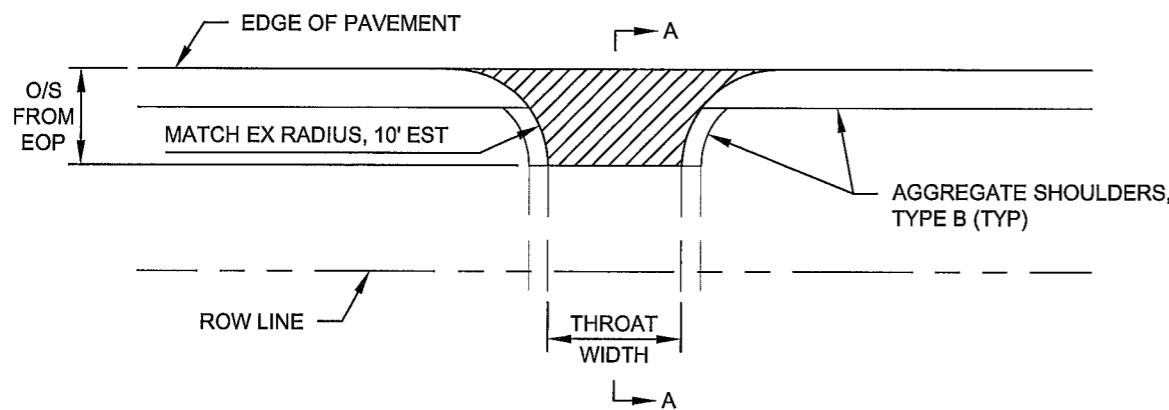

TYPICAL PRIVATE / COMMERCIAL ENTRANCE

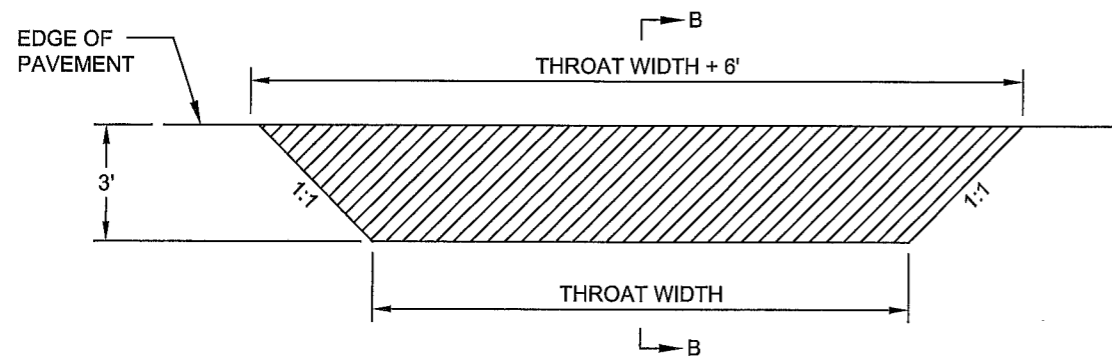

TYPICAL FIELD ENTRANCE

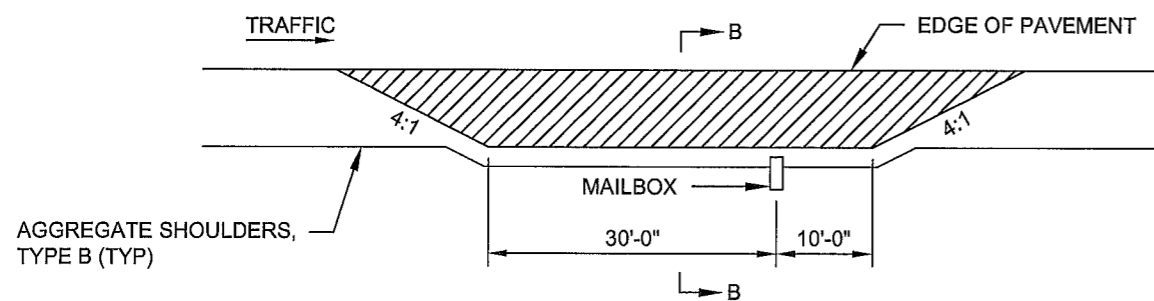

TYPICAL MAILBOX TURNOUT

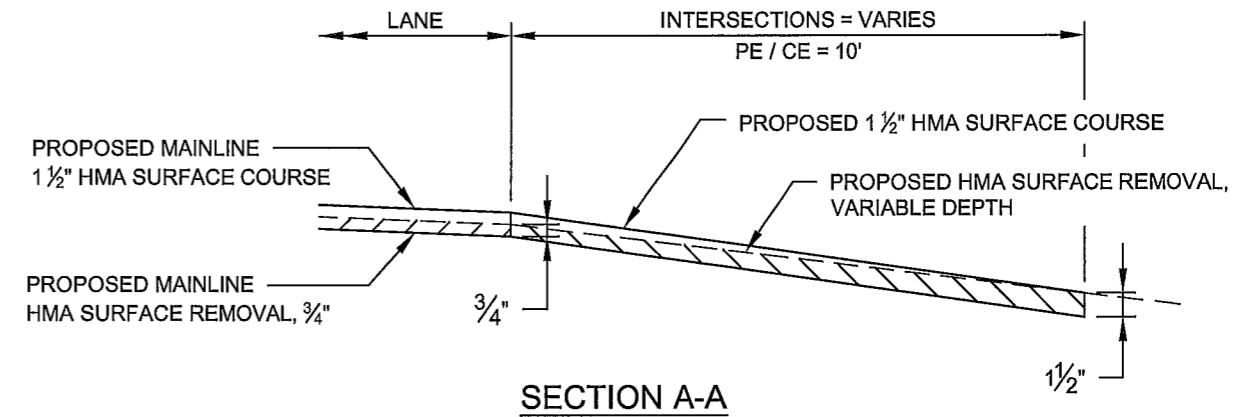

SECTION A-A

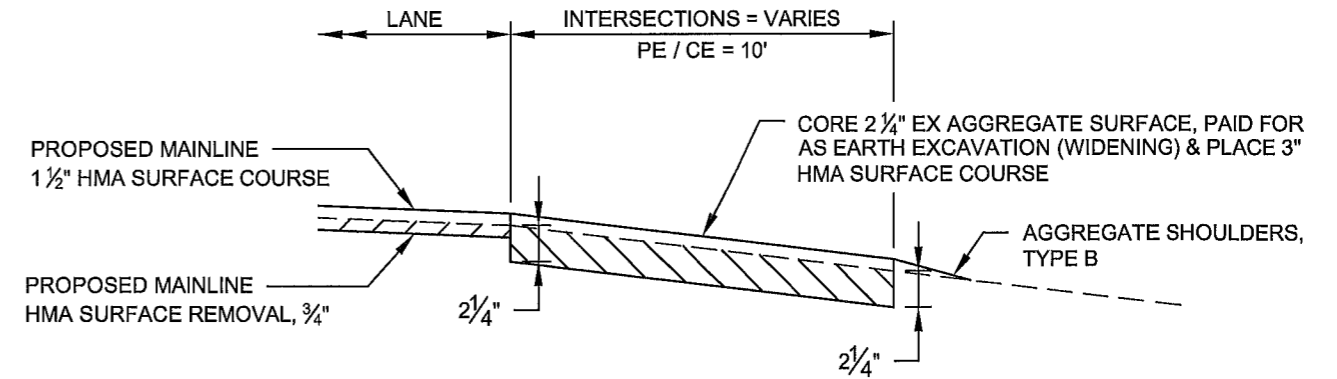

SECTION A-A
EXISTING AGGREGATE SURFACE

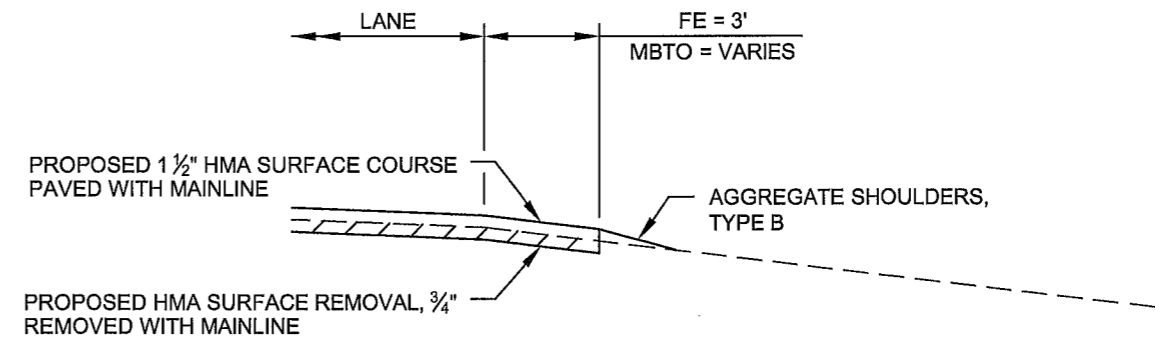

SECTION B-B

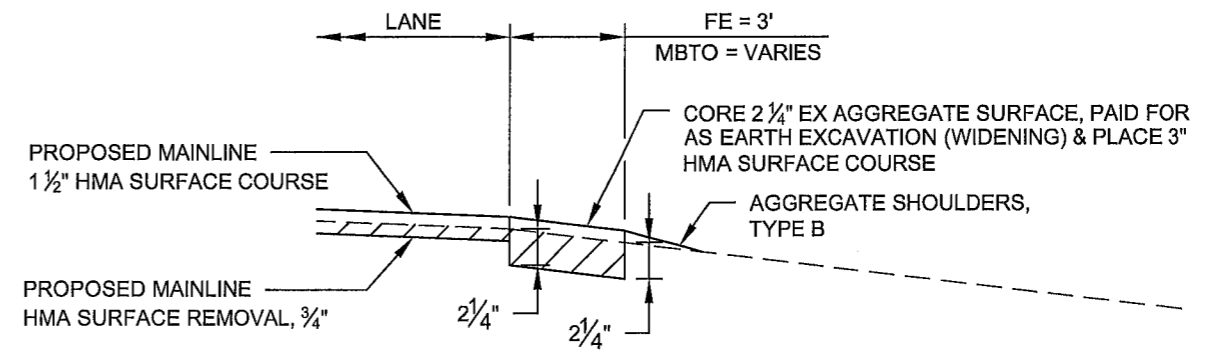

SECTION B-B
EXISTING AGGREGATE SURFACE

SECTION

23-00409-00-RS

DETAILS

LASALLE COUNTY
HIGHWAY DEPARTMENT
1400 N. 27TH ROAD - P.O. BOX 128 - OTTAWA, ILLINOIS 61350
PHONE (815) 434-0743 FAX (815) 434-0747



HWY. NO.

CH 15

SHEET NO.

10 of 11

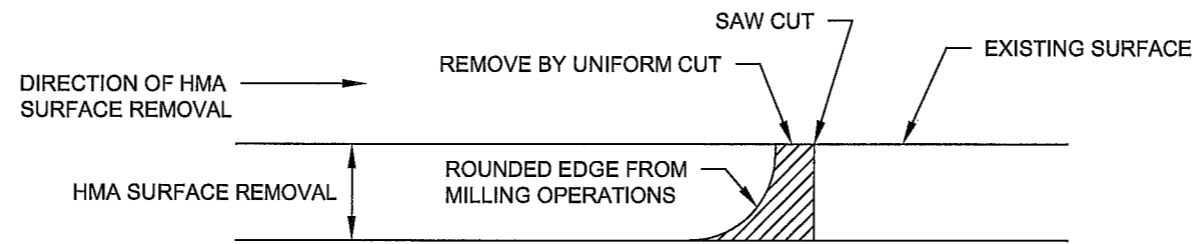

DETAIL A

WHEN MILLING OPERATIONS PRODUCE A ROUNDED EDGE, A SAW CUT SHALL BE USED TO MANUFACTURE A PERPENDICULAR EDGE AS SHOWN IN THE DETAIL. THE ENGINEER SHALL BE THE SOLE JUDGE CONCERNING THE USE OF THIS DETAIL. THE COST OF SAW CUTTING AND REMOVAL IS INCLUDED IN THE COST OF THE MILLING OPERATION.

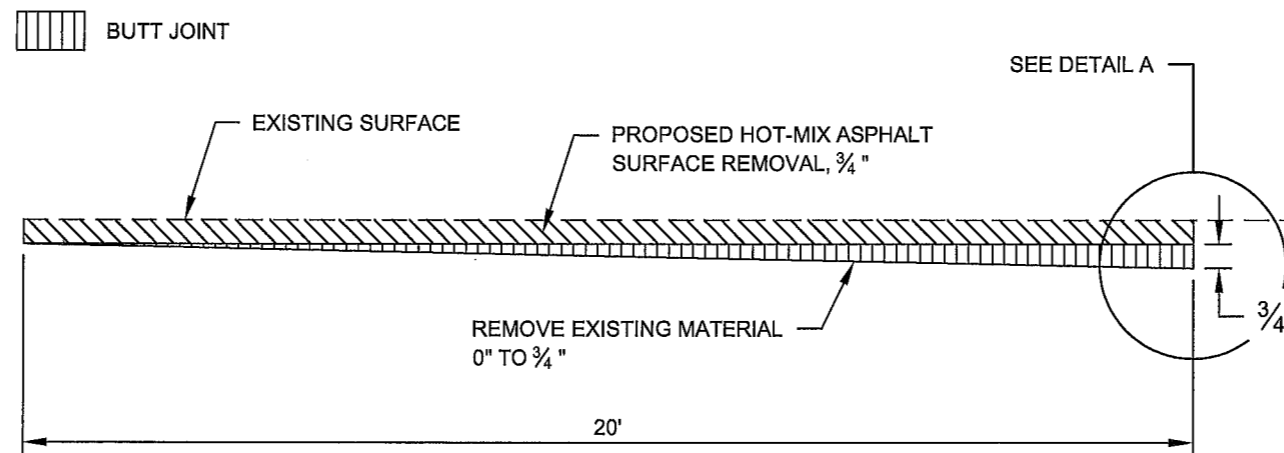

BUTT JOINT DETAIL

SEE HOT-MIX ASPHALT SURFACE REMOVAL - BUTT JOINT SCHEDULE FOR LOCATIONS

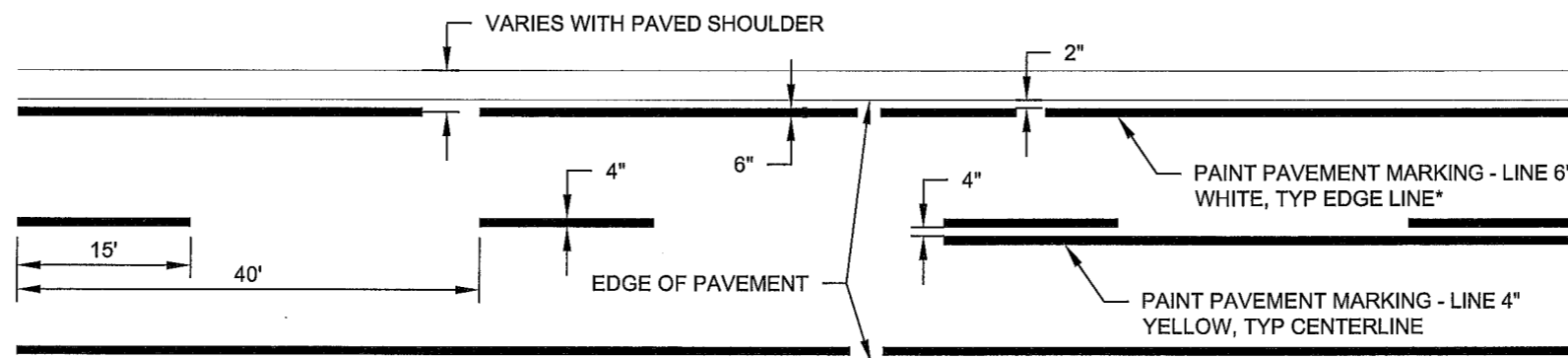

**PAVEMENT STRIPING DETAIL
LASALLE COUNTY**

LASALLE COUNTY MAINTAINS A TWO GUN SYSTEM. PAINT OPERATION SHOULD REFLECT LASALLE COUNTY'S SYSTEM

SECTION

23-00409-00-RS

DETAILS

LASALLE COUNTY
HIGHWAY DEPARTMENT
1400 N. 27TH ROAD - P.O. BOX 128 - OTTAWA, ILLINOIS 61350
PHONE (815) 434-0743 FAX (815) 434-0747



HWY. NO.

CH 15

SHEET NO.

11 of 11